



FS-N41N

Fibre Amplifier, Cable Type, Main Unit, NPN



SPECIFICATIONS

Model	FS-N41N	
Type	Cable	
Output type	NPN	
Main unit/expansion unit	Main unit	
Number of control outputs	1	
Number of external inputs	-	
Light source LED	Transmitter side: Red, four-element LED (wavelength 660 nm)	
Response time	23 μ s (S-HSPD ^{*1}) / 50 μ s (HSPD ^{*2}) / 250 μ s (FINE) / 500 μ s (TURBO) / 1 ms (SUPER) / 4 ms (ULTRA) / 16 ms (MEGA) / 64 ms (TERA)	
Control output	Open-collector, 30 V or less 100 mA or less per output, 100 mA or less total for 2 outputs (when used as a solitary unit) / 20 mA or less (when used as an expansion unit) Residual voltage: 1.4 V or less (output current 10 mA or less) / 2 V or less (output current 10 to 100 mA)	
External input	Input time 2 ms (ON) / 20 ms (OFF) or longer ^{*3}	
Unit expansion	Up to 16 units (17 units connected in total including the main unit). However, each dual output type will be treated as two expansion units.	
Protection circuit	Protection against reverse power connection, output overcurrent, output surge, and reverse output connection	
Mutual interference prevention	S-HSPD/HSPD 0 units, FINE 4 units, TURBO/SUPER/ULTRA/MEGA/TERA 8 units (The mutual interference prevention values are twice those shown here when Double is set.)	
Power supply	Power voltage	10 to 30 VDC (including 10% ripple (P-P) or less), class 2 or LPS ^{*4}
	Current consumption	During normal operation: 870 mW or less (34 mA or less at 24 V/62 mA or less at 12 V) ECO ON: 800 mW or less (31 mA or less at 24 V/56 mA or less at 12 V) ECO FULL: 710 mW or less (28 mA or less at 24 V/49 mA or less at 12 V) ^{*5}
Environmental resistance	Ambient light	Incandescent lamp: 20,000 lux or less, sunlight: 30,000 lux or less
	Operating ambient temperature	-20 °C to +55 °C (no freezing) ^{*6}
	Vibration resistance	10 to 55 Hz; double amplitude 1.5 mm; 2 hours each for X, Y, and Z axes
	Shock resistance	500 m/s ² ; 3 times each for X, Y, and Z axes
Case material	Main unit and cover: polycarbonate	
Weight	Approx. 78 g	
<p>^{*1} Restrictions when S-HSPD is selected Area detection, Area % Mode, DATUM, Rising edge, and Falling edge cannot be selected for Detection Mode. Output timer, Limit Detection, and Display Gain cannot be used. FULL cannot be selected for the ECO function.</p> <p>^{*2} Restrictions when HSPD is selected Display Gain cannot be used.</p> <p>^{*3} The input time becomes 25 ms (ON)/25 ms (OFF) when external calibration input is selected.</p> <p>^{*4} When expanding the system to 9 or more units, use a power supply voltage of 12 V or higher.</p> <p>^{*5} The load current is excluded. The power consumption including the load when the maximum number of units are connected is 38 W max.</p> <p>^{*6} When expanded by 1 to 2 units: -20 °C to +55 °C. When expanded by 3 to 10 units: -20 °C to +50 °C. When expanded by 11 to 16 units: -20 °C to +45 °C. When using 2 outputs, 1 unit is counted as 2 units. The prescribed values for the ambient temperature assume that the sensor amplifier has been mounted on a DIN rail installed on a metal surface. Exercise special care when installing the product in an airtight space.</p>		

Dimensions

* Download CAD file or product manual for larger image/text and more detail.

fs-n41_n43_dimension_01.gif

FS-N41N/N41P/N43N/N43P Main Unit (Cable Type)

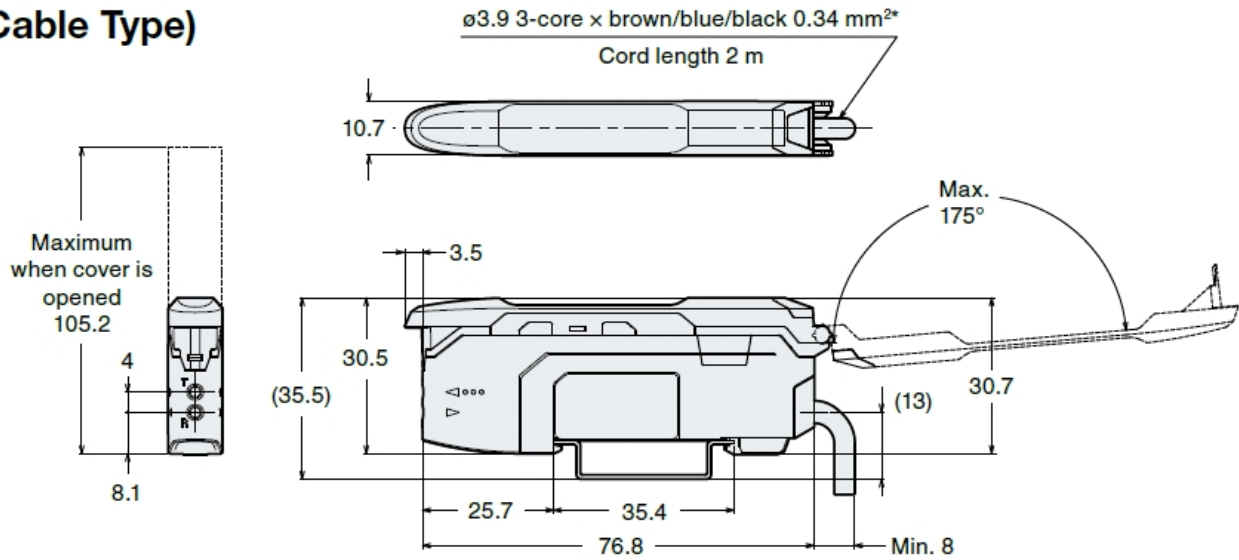

* FS-N43N/N43P is $\varnothing 3.9$, 5-core x brown/blue 0.34 mm², black/white/pink 0.18 mm²

Amplifier Securing Bracket (OP-88245 Option, Sold Separately)

Cable Type

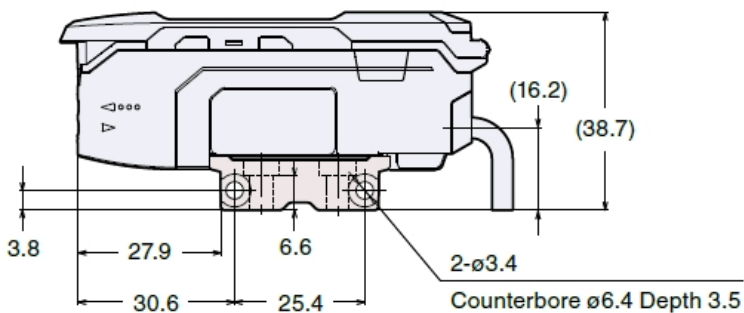

Back of securing bracket

