

# KEYENCE

## Safety Light Curtain SL-V Series

Maximum safety standard

**Type4** **SIL3** **Category4** **PLe**



# Super Slim



# Super Heavy Duty



## You Will **SEE** the Difference!



Standard



Heavy duty



Safety Relay  
Terminal  
**SL-T11R**



PC Configuration  
Software  
**SL-VH1S**

# Lightweight & Super Slim Body Makes Compact Installation Possible

Visible Safety Light Curtain

# Super Slim



World's first

Highly-Visible Indicators

Visible  
Safety Light Curtain

## SL-V Series Full Lineup



SL-VF Series



SL-VH Series

## Additional New Safety Equipment



Exclusively for  
the SL-V Series  
Relay Terminal  
**SL-T11R**

Designed for use  
in tough environments

Visible Safety Light Curtain

# Super Heavy Duty



SL-VFM Series



SL-VHM Series



World's first

Highly Visible  
Indicators

The SL-V Series  
meets IP67 standards  
without the need for  
any additional  
accessories



The SL-V Series conforms  
to IP65 and IP67 based  
on IEC/JIS standards

No damage  
from shock



This model can be used in  
places where workpieces  
often strike the unit.



PC Configuration  
Software  
**SL-VH1S**

Interface Unit  
**SL-V1UB**

USB Cable  
**OP-51580**  
(Include with  
the SL-V1UB)

# New Version Information for **All SL-V** Series Models

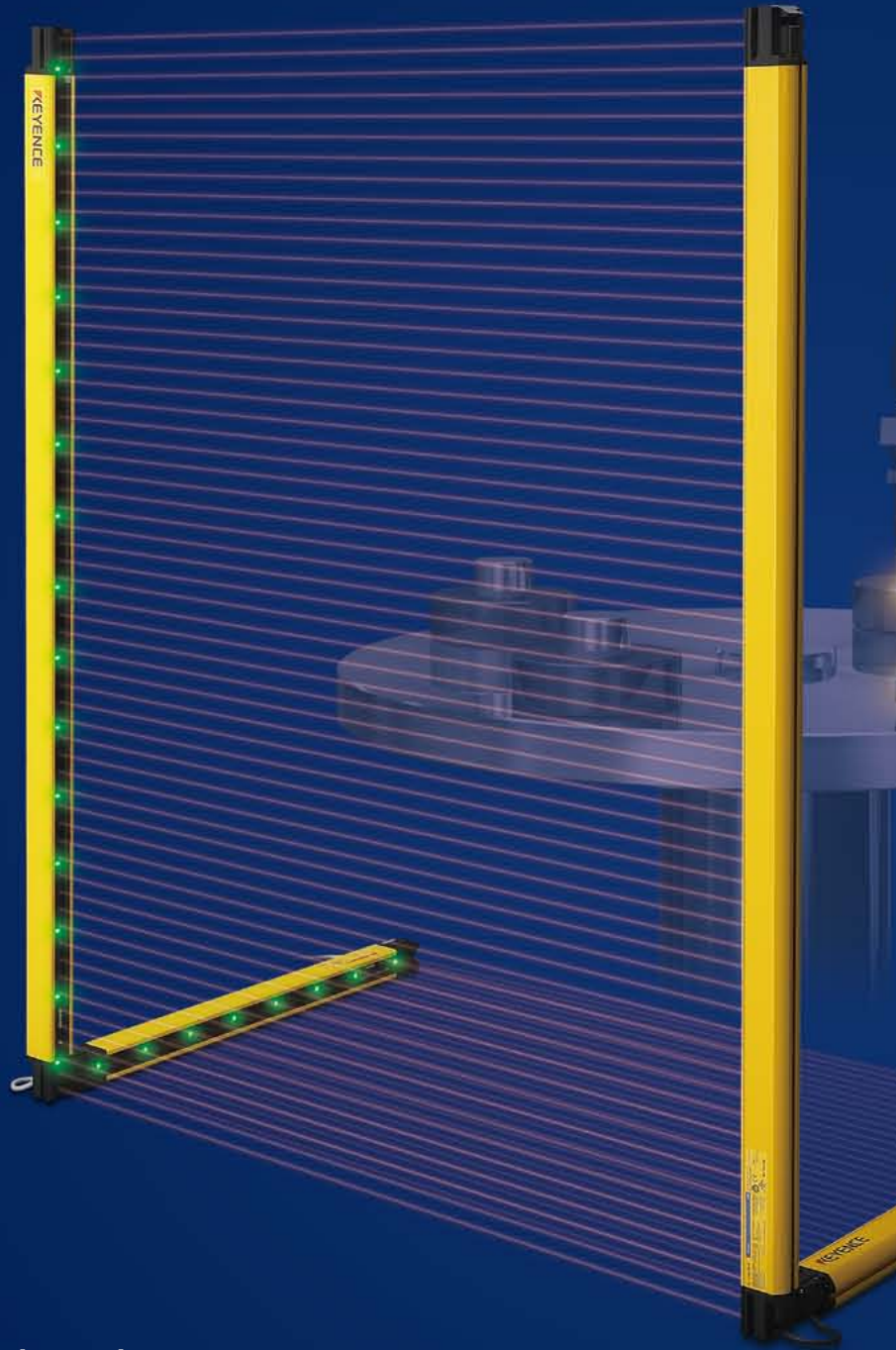

With the new functions, it is no longer necessary to purchase an additional control unit. Functions like muting and beam axis intensity monitoring that used to be difficult or impossible, are now easy to setup using the software. As a result, on-site installation time will be greatly reduced.

## Programmable Muting function

Programmable Muting allows the user to customise what parts of the safety curtain are suspended. Up to three different clearance heights can be programmed so that the user can easily pass different height parts while maintaining maximum safety.



**Clearance height 1**  
(The height of the work piece : low)



**Clearance height 2**  
(The height of the work piece : high)

## Fixed Blanking function

This function is used when an obstacle is always within the detection area. It makes it possible to operate a safety light curtain normally even with an obstacle present.



## Reduced Resolution function

This function is used when an obstacle moves within the detection area. The output turns off only if the light is blocked in more optical axes than the set number.



## The SL-VH1S PC configuration software Makes It Possible to **Reduce** The On-Site **Installation Time!**

### Required System Environment



SL-VH1S



## The Configuration Software Makes it Possible to —

### Monitor received light intensity of beam axes

It gives the user a visual indication of beam strength for alignment, troubleshooting, or initial setup.

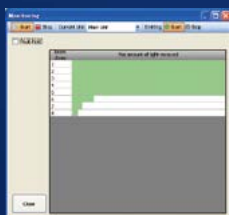

### Precisely configure the Muting function

It can be used to choose which beams are used for Muting and Blanking functions with a PC.



### Customise the Highly-Visible Indicators

It allows the operator to select how the Highly-Visible Indicators spanning the whole curtain will light or flash and what colour they will be for different conditions. This helps the user to see the current operating status of the safety light curtain.

### Configure the Override function

The SL-VH1S software can be used to adjust the time limit of the Override function from the default 60 seconds to as much as 15 minutes.

### Configure the EDM function

The EDM makes it possible to monitor external devices such as contactors. The SL-V configuration software (SL-VH1S) allows the user to select whether or not to use the EDM function and to select permissible times for it.

### Configure the Interlock function

Easily configure how to reset the light curtain(Interlock function) under the following two conditions.

- Upon startup: Automatic or Manual
- After an obstruction: Automatic or Manual

# Introducing the user-friendly safety relay

**1. Quick Connector**

**2. Replaceable Relay**

**3. Dedicated Power Supply**

## SL-T11R Type4 Safety Relay Terminal

The SL-T11R combines all of the features necessary to build a Category 4 compatible safety circuit into a single unit. This makes it possible to dramatically reduce the amount of time and labour required by complex circuit design processes. It also boasts quick connectors that simplify the wiring process involved in connecting the relay to the light curtain itself. The SL-T11R eliminates the need for specialised knowledge about safety circuits.



### Quick Connector

The safety light curtain is connected via a quick connector, eliminating the danger of wiring mistakes and reducing the amount of time and labour required for wiring.



### Space-saving

The SL-T11R case design ensures that the connectors do not extend outside of the unit's footprint, helping to save space inside control panels.



### Replaceable Relay

The relay board (OP-84388) can be replaced without removing any wires which eliminates time loss and potential connection mistakes during board rewiring.

\*The terminal unit can also be removed separately.

## SL-U2 AC Power Supply



The SL-U2 dedicated power supply directly connects to the side of the SL-T11R, providing power to the entire light curtain setup without the need for additional wiring.

For safety and efficiency in the workplace

# Introducing a safety light curtain completely focused on visibility

SL-V

1 Quickly recognise the status of the safety light curtain  
**Visible/Identifiable Indicator**

2 Installation style that fits the setup with no dead zone  
**Edge-to-Edge Construction**

3 Reduce No. of parts and mounting processes  
**Built-in Safety Controller Function**  
[EDM function, muting function]

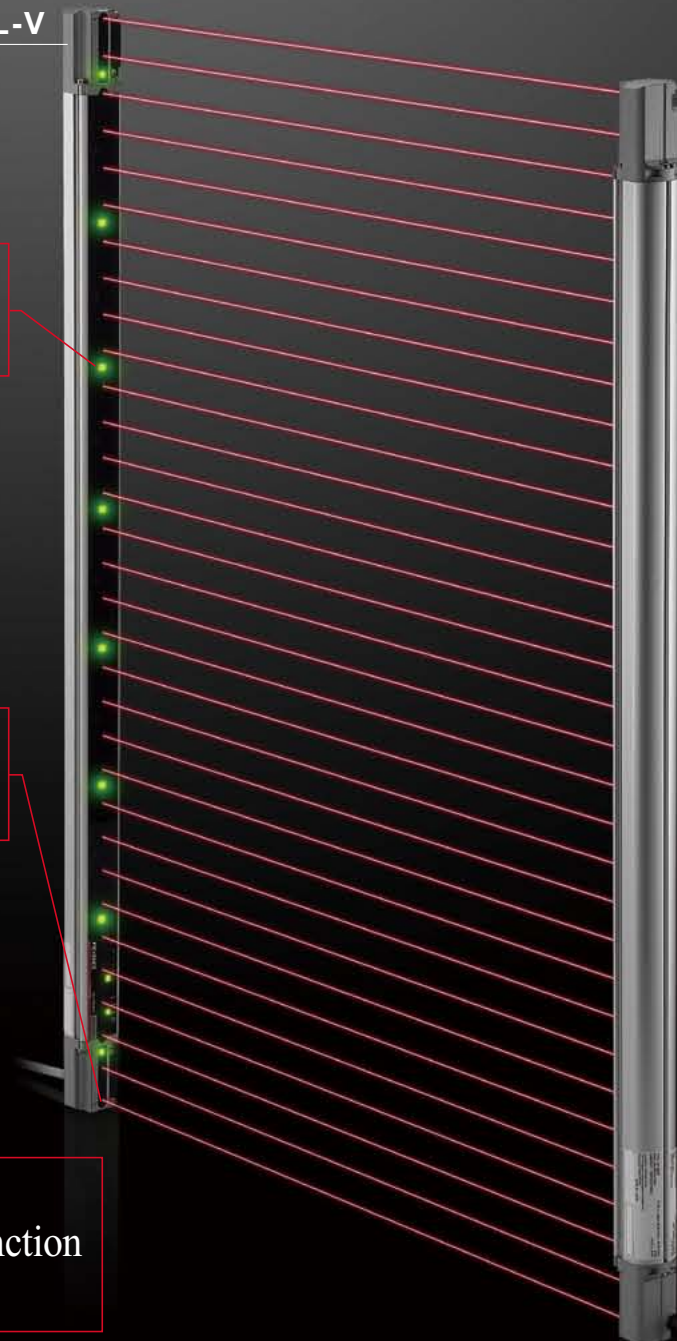

# 1 Quickly recognise the presence of a safety light curtain Visible/Identifiable Indicator

## Know Immediately Whether The Safety Light Curtain Is Active

### I Clear status indication

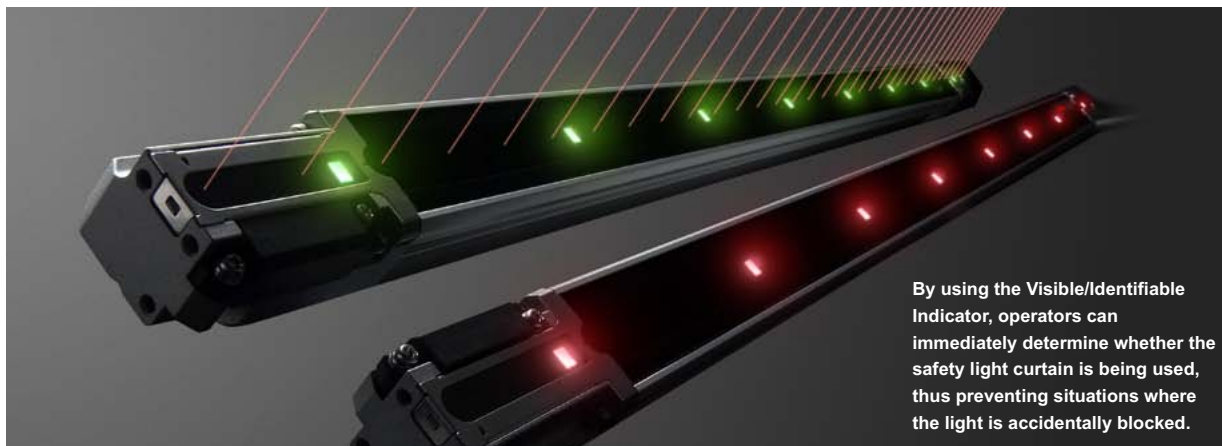

### Visible [1] Clear Status Indication

The status of the safety light curtain can be easily determined by the blinking or lighting. The cause can be easily identified if the safety curtain does not start up.

#### I During operation



During normal operation, there is no interruption in the detection zone.

The beam axes are misaligned or dirty, or there is interruption in the detection zone.

An error (such as a malfunction in an external device) has occurred.

#### I During startup



There is an error due to wrong wiring or similar problems.

The beam axes are misaligned, not due to damage or a similar error.

### Visible [2] 3 Step Adjustment Easy Beam Axis Alignment

Using the Visible Indicator, beam axis alignment can be performed in just three steps.

#### STEP 1 Align the top row

The indicators at the top light up when the top beam axis is aligned.



#### STEP 2 Align the bottom row

All of the indicators light red when the bottom beam axis is aligned.



#### STEP 3 Fine-tune the rotational direction

All of the indicators light green when all of the beam axes are aligned.

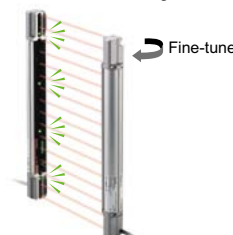

# 2 Installation style that fits the setup

## Edge-to-Edge construction

### NO DEAD ZONE

With the first beam axis placed right along the edge and cables drawn to the side, detection can be performed along the entire area. Since there is no need to install it outside of the sensing area in order to cover the dead zone, the light curtain can fit snugly into the setup.

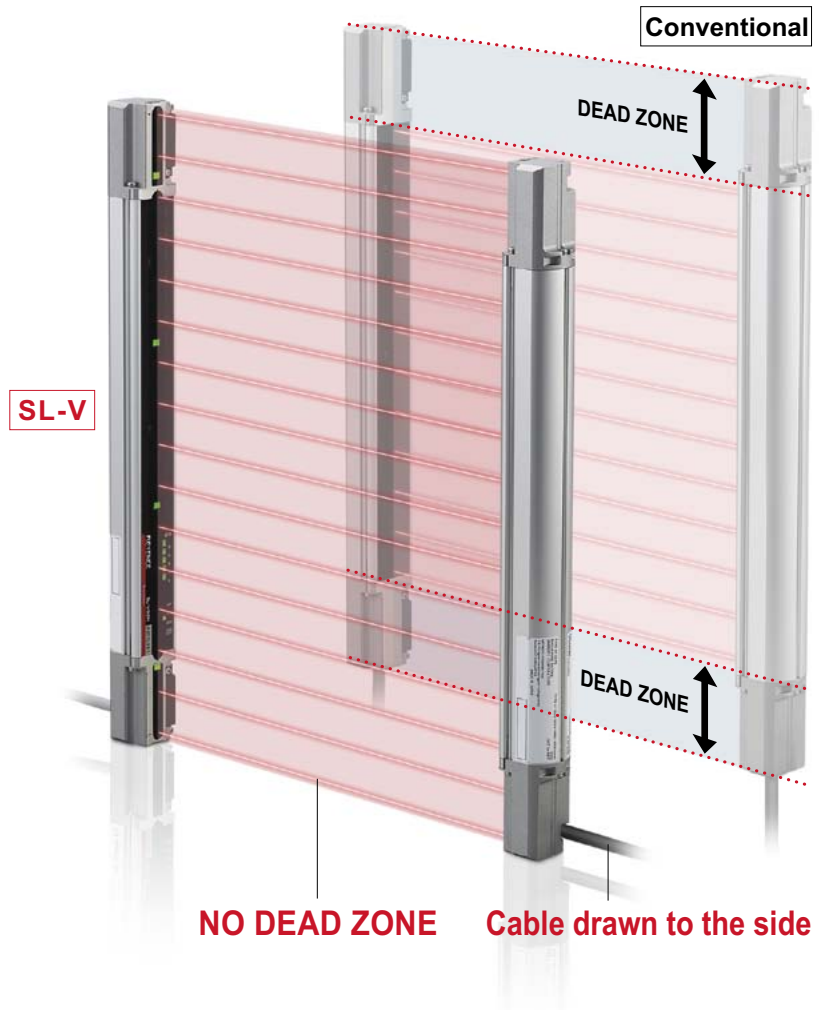

### 1 Outside installation

[Sticking out]

Conventional

In order to cover the top and bottom dead zones, the light curtain is installed outside of the entrance.



It sticks out from the setup and interferes with operations.

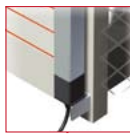

With the SL-V, there is NO DEAD ZONE



### 2 Inside installation

[Creating dead zone]

Conventional

Install an additional protection plate



Preparing the protection plate is annoying



- ⦿ Does not stick out
- ⦿ No additional protection plate needed

### 3 Series connection

[Creating dead zone]

Conventional

Cannot avoid dead zone



Creates double dead zone

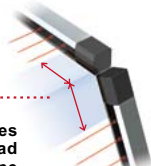

With the SL-V, there is NO DEAD ZONE



- ⦿ Up to 3 units can be connected in series



# 3 Reduce No. of parts and mounting processes

## Built-in Safety Controller Function

Direct link to an external device

### Compliance with Category 4 requirements without a Safety Relay Unit

With a built-in external device monitoring (EDM) function, the requirements for category 4 can be fulfilled without a safety relay unit. The maximum capacity that can be controlled with the OSSD output is a current load up to 500 mA, thus allowing direct driving of external devices\*.

Reduce cost

Shorten safety distance

\* External devices cannot be used if the input current exceeds 500 mA.

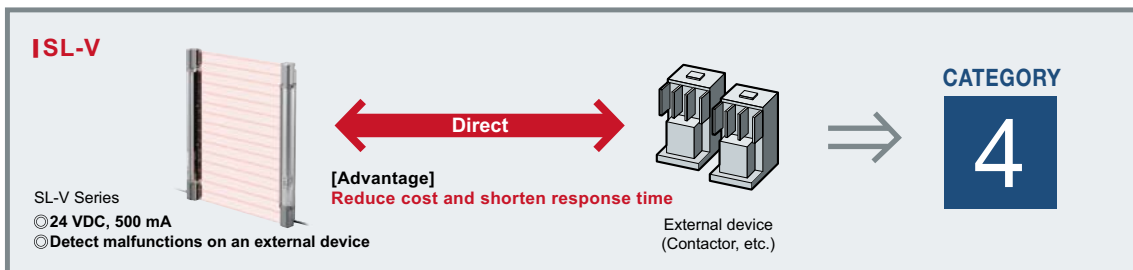
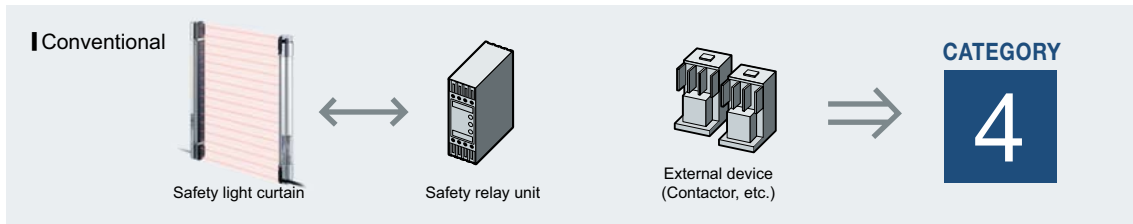

Built-in muting function

### Perform Muting without a Dedicated Controller

The SL-V has built-in muting functions, so a safety control circuit can be constructed without a dedicated controller. Using the State Information Output, the SL-V status can be sent to a standard (non-safety) PLC.

Reduce cost

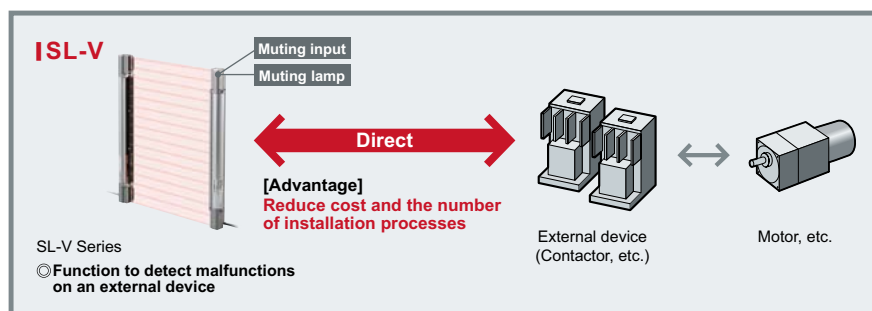
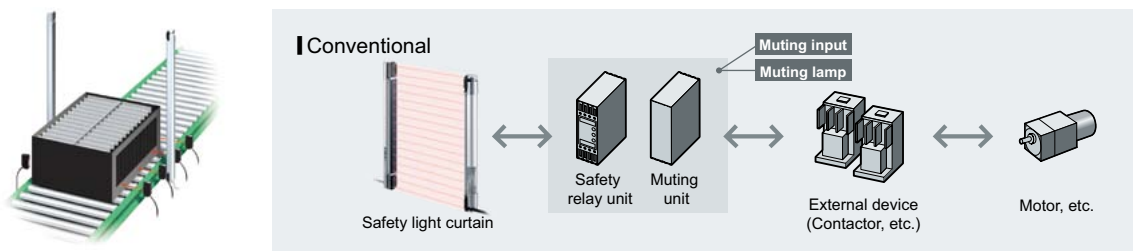

Improved upon the demands of electricity supervisors to make the safety light curtain easier to use

## Distinguish between safety output off and error off

### Separate Alert Output

Many operators wanted a function that would not just simply turn the safety light curtain on or off, but instead clearly indicate the error\*. In response to this request, the alert output (lockout output) can be used additionally. The warning indicator lights up only when there is an error.

\*Welding or disconnection of relays in the external device, or sensor damage etc.



Lights only when there is an error in the lockout output



Conventional output

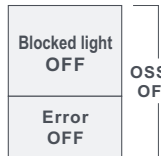

After improvement

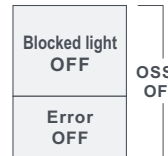

In addition to the OSSD output, Error OFF can be output additionally.



## Send the type of error or muting state to a PLC

### State Information Output

This function is a function to inform the PLC or other external device (non-safety-related device) of the current state of the safety light curtain. The current state can be identified in real time, so the State Information can be displayed on a touch panel and the state history saved.

Error cause analysis

Control interlock

State Information output has two modes: Normal mode (default) and Simple mode.

**Useful input/output functions are also included for startup and maintenance (non-safety-related function).**

- I/O monitoring function: Checks whether the wiring is performed correctly.
- AUX (auxiliary output): Auxiliary output performs the same operations as the OSSD output.
- Wait (Stop) input: A signal from an external device causes forcible OSSD-OFF.

[ IP 6 7 ]

# Introducing Our Tough, Water-proof Model



Tough, water-proof SL-VHM Series

## Tough, slim construction

With older methods, a thick cover had to be used for protection in order to increase the strength, but the SL-VHM model achieves a tough, slim body.

### Simple function type SL-VH

The strength is unstable with the simple function type depending on the type of workpiece.



### Visible Tough, water-proof type SL-VHM

The conventional tough models were very thick, but the new model has achieved a slim structure.



## IP 6 7

The specifications clear both IP67 and IP65 based on IEC standards.

No damage when wet



## No damage from shock



This model can be used even if workpieces often strike the unit.

## No misalignment from shock



Tough fixtures and strong holding power ensure that the beam axes do not become misaligned if struck.

## Optional front protection cover



Use an optional front protection cover to protect the detector from stains or splatter.

## Up to 3 units in series connection



Series connection can be used with up to three units. This is useful for reducing wiring in situations such as using a perpendicular unit between two parallel units. This model can also be connected to the simple function type

## New built-in functions

Visible/Identifiable Indicator	Muting Function
State Information Output	EDM Function
Lockout Output	Interference Reduction Function

The same functions as the SL-VH Series can be used.

# Selecting a Safety Light Curtain

Use the following steps to help select the optimum SL-V Series model according to your situation.

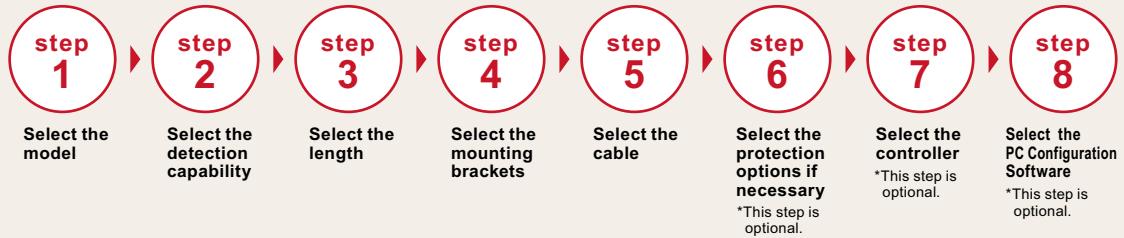

## SL-V Series LINE-UP

### step 1 2 3 Light Curtain



**Finger Detection  
SL-VF Series**  
Detection capability  
ø14 mm



**Finger Detection  
Tough, water-proof  
SL-VFM Series**  
Detection capability  
ø14 mm



**Hand Detection  
SL-VH Series**  
Detection capability  
ø25 mm



**Hand Detection  
Tough, water-proof  
SL-VHM Series**  
Detection capability  
ø25 mm

### step 4 mounting bracket



### step 5 cable



### step 6 protection options



### step 7 controller



### step 8 PC Configuration Software



PC Configuration  
Software  
SL-VH1S

Interface Unit  
SL-V1UB

USB Cable  
OP-51580  
(Include with  
the SL-V1UB)

## step 1 Select the type of model

Select a simple function type or tough, water-proof type depending on the operating environment.



For a normal environment

### ▶ Slim type

Select the detection capability (ø14/ø25 mm).

Go to step 2.



For good operations under shock or wet environments

### ▶ Tough, water-proof type

Select the detection capability (ø14/ø25 mm).

Go to step 2.



## step 2 Select the detection capability for the model

Only if "Simple function type" was selected in step 1.

Select the value according to the distance from the source of the hazard.



For a short distance to the hazard source

### ▶ Detection capability: ø14 mm (Detection for a finger)

Beam axis pitch of 10 mm. This is the safest type available.

Intrusion detection

For simple function type

Go to step 3.



For tough, waterproof type

Go to step 3: SL-VFM.



For the most widely used, standard type

### ▶ Detection capability: ø25 mm (Detection for a hand)

Beam axis pitch of 20 mm.

Intrusion detection

For simple function type

Go to step 3.



For tough, waterproof type

Go to step 3: SL-VHM.



### step 3 Select the length of the model

Select the necessary length from the specifications chart for the series suggested by step 1 and step 2.

▼ If "ø14 mm (detection for a finger)" was selected in step 2

#### SL-VF Series

[Detection capability: ø14 mm]

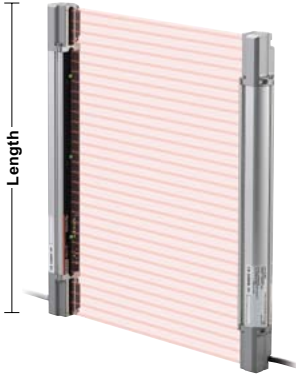

Beam axis pitch	Detection capability
10 mm	ø14 mm

Select the length. The item to the left of the selected length represents the model for the appropriate safety light curtain.

Model	Length (mm)	No. of axes	Detection height (mm)	Protection height (mm)	Operating distance (m)
SL-V23F	230	23	220	244	0.1 to 7
SL-V31F	310	31	300	324	
SL-V39F	390	39	380	404	
SL-V47F	470	47	460	484	
SL-V55F	550	55	540	564	
SL-V63F	630	63	620	644	
SL-V71F	710	71	700	724	
SL-V79F	790	79	780	804	
SL-V87F	870	87	860	884	
SL-V95F	950	95	940	964	
SL-V103F	1030	103	1020	1044	
SL-V111F	1110	111	1100	1124	
SL-V119F	1190	119	1180	1204	
SL-V127F	1270	127	1260	1284	

Go to step 4.

▼ If "ø25 mm (detection for a hand)" was selected in step 2

#### SL-VH Series

[Detection capability: ø25 mm]

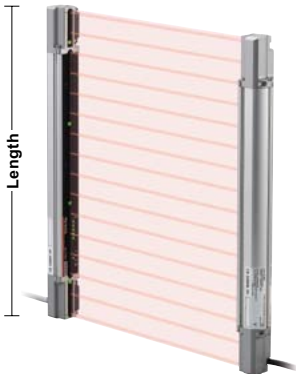

Beam axis pitch	Detection capability
20 mm	ø25 mm

Select the length. The item to the left of the selected length represents the model for the appropriate safety light curtain.

Model	Length (mm)	No. of axes	Detection height (mm)	Protection height (mm)	Operating distance (m)
SL-V08H	150	8	140	185	0.1 to 9
SL-V12H	230	12	220	265	
SL-V16H	310	16	300	345	
SL-V20H	390	20	380	425	
SL-V24H	470	24	460	505	
SL-V28H	550	28	540	585	
SL-V32H	630	32	620	665	
SL-V36H	710	36	700	745	
SL-V40H	790	40	780	825	
SL-V44H	870	44	860	905	
SL-V48H	950	48	940	985	
SL-V52H	1030	52	1020	1065	
SL-V56H	1110	56	1100	1145	
SL-V60H	1190	60	1180	1225	
SL-V64H	1270	64	1260	1305	
SL-V72H	1430	72	1420	1465	0.1 to 7
SL-V80H	1590	80	1580	1625	
SL-V88H	1750	88	1740	1785	
SL-V96H	1910	96	1900	1945	
SL-V104H	2070	104	2060	2105	
SL-V112H	2230	112	2220	2265	
SL-V120H	2390	120	2380	2425	

Go to step 4.

#### SL-VL Series

[Detection capability: ø45 mm]

Beam axis pitch	Detection capability
40 mm	ø45 mm

Limb detection model is also available.

[SL-VL Series]

For more information about the model and specifications, contact your nearest KEYENCE office.

▼ If "Tough, water-proof type" was selected in step 1

## SL-VFM Series

[Tough, water-proof type.  
Detection capability:  $\varnothing 14$  mm]



Beam axis pitch	Detection capability
10 mm	$\varnothing 14$ mm

☑ Select the length. The item to the left of the selected length represents the model for the appropriate safety light curtain.

Model	Length (mm)	No. of axes	Detection height (mm)	Protection height (mm)	Operating distance (m)
SL-V23FM	246	23	220	244	0.1 to 7
SL-V31FM	326	31	300	324	
SL-V39FM	406	39	380	404	
SL-V47FM	486	47	460	484	
SL-V55FM	566	55	540	564	
SL-V63FM	646	63	620	644	
SL-V71FM	726	71	700	724	
SL-V79FM	806	79	780	804	
SL-V87FM	886	87	860	884	
SL-V95FM	966	95	940	964	
SL-V103FM	1046	103	1020	1044	
SL-V111FM	1126	111	1100	1124	
SL-V119FM	1206	119	1180	1204	
SL-V127FM	1286	127	1260	1284	

Go to step 4.

Select the mounting bracket for the tough, waterproof type.

▼ If "Tough, water-proof type" was selected in step 1

## SL-VHM Series

[Tough, water-proof type.  
Detection capability:  $\varnothing 25$  mm]



Beam axis pitch	Detection capability
20 mm	$\varnothing 25$ mm

☑ Select the length. The item to the left of the selected length represents the model for the appropriate safety light curtain.

Model	Length (mm)	No. of axes	Detection height (mm)	Protection height (mm)	Operating distance (m)
SL-V12HM	246	12	220	265	0.1 to 9
SL-V16HM	326	16	300	345	
SL-V20HM	406	20	380	425	
SL-V24HM	486	24	460	505	
SL-V28HM	566	28	540	585	
SL-V32HM	646	32	620	665	
SL-V36HM	726	36	700	745	
SL-V40HM	806	40	780	825	
SL-V44HM	886	44	860	905	
SL-V48HM	966	48	940	985	
SL-V52HM	1046	52	1020	1065	
SL-V56HM	1126	56	1100	1145	
SL-V60HM	1206	60	1180	1225	
SL-V64HM	1286	64	1260	1305	
SL-V72HM	1446	72	1420	1465	0.1 to 7
SL-V80HM	1606	80	1580	1625	
SL-V88HM	1766	88	1740	1785	
SL-V96HM	1926	96	1900	1945	

Go to step 4.

Select the mounting bracket for the tough, waterproof type.

### I Understanding the model name

**SL-V 12 H M**

1      2      3      4

- Series name
- No. of beam axes: 2 or 3 digit number.  
Ex: 08 = 8 axes, 64 = 64 axes
- Detection capability: F:  $\varnothing 14$  mm detection type, H:  $\varnothing 25$  mm detection type
- Special type: Unmarked: Simple function type, M: Tough, water-proof type

### I Meaning of each item

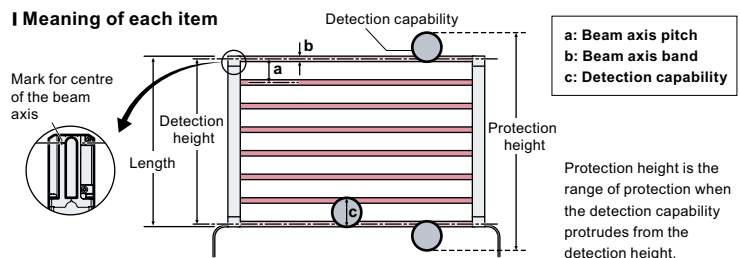

## step 4 Select the mounting bracket for the model

Select the correct bracket for the product series or the installation environment.

For SL-VF/VH **360° rotation standard type**

### ▶ Standard mounting bracket

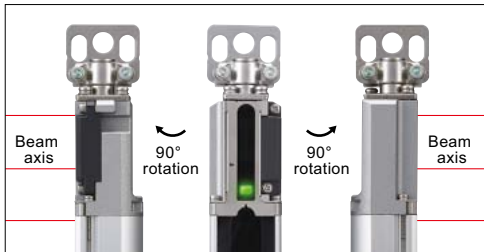

\*This bracket allows 360° rotation, so it can be rotated towards the installation side.

▶ Compact and aluminium frame for single-point installation



Standard mounting bracket J  
OP-83180

▶ Easy-to-install, long-holed type that can be used in previous installation holes



Standard mounting bracket A  
OP-42347



Standard mounting bracket B  
OP-42348



Standard mounting bracket C  
OP-42349

Go to step 5. ▶

For SL-VF/VH **180° rotation, space-saving type**

### ▶ Thin mounting bracket

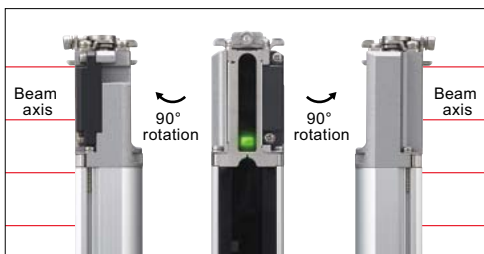

Thin mounting bracket  
OP-51698

Go to step 5. ▶

For SL-VF/VH **For bent, L-shaped mounting**

### ▶ L-shaped mounting bracket

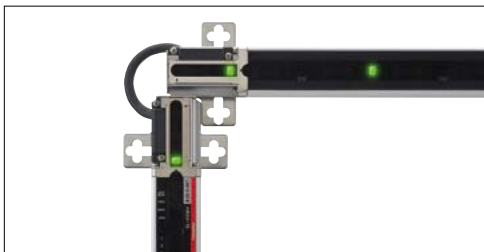

L-shaped mounting bracket  
OP-42371

\*Cannot be rotated.

\*L-shaped installation is also possible with OP-83181 and OP-42370.

Go to step 5. ▶



**Note** Mounting brackets are sold separately.

- Note**
- Mounting brackets all come two pieces to a set. Two sets are required to install the model (transmitter and receiver).
  - Depending on the length, the intermediate support bracket OP-83181 or OP-42370 may also be required. For the number of required brackets, see pages 32 and 33.
  - The installation screws for the installation frame are not included. When using standard mounting brackets A/B/C/J or the L-shaped mounting bracket, M5 screws are required. M6 screws are required for SL-VHM, and M4 screws for all other models. Purchase the necessary number of screws for installation.

**For SL-VF/VH** If mounting brackets cannot be used on the upper or lower side on the light curtain

## ▶ E-to-E mounting bracket

If the safety light curtain is long, intermediate support brackets or L-shaped brackets can also be used.

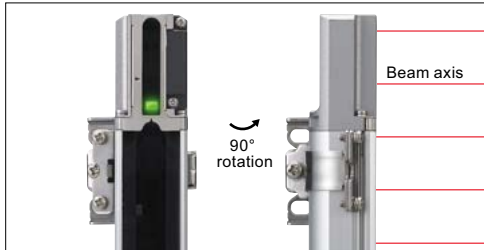

\*The figure shows an example of the installation holes facing the left. They can also be turned to face the right.

▶ **Minimise one side of mounting**



Compact E-to-E bracket  
OP-83181

▶ **Firmly secured at four points.**



E-to-E bracket  
OP-42370

Go to step 5. ▶

**For SL-VFM/VHM** Dedicated standard mounting bracket for the tough, water-proof type

## ▶ Tough standard mounting bracket

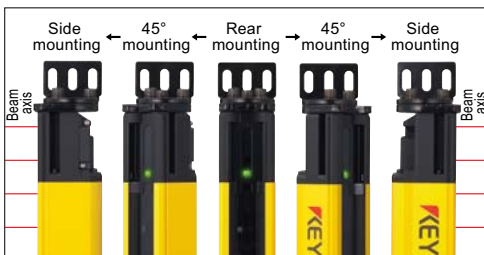

\*There are five possible mounting patterns that can be achieved by changing the screw position.



Standard mounting bracket  
OP-84259

Go to step 5. ▶

**For SL-VFM/VHM** Specialised tough, water-proof type, if mounting brackets cannot be used on the upper or lower side on the light curtain

## ▶ Tough, space-saving mounting bracket

If the safety light curtain is long, intermediate support brackets or L-shaped brackets can also be used.

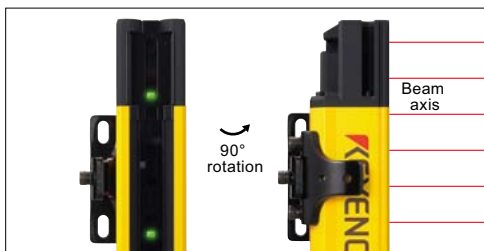

\*The bracket can be rotated 90° by changing the position of the three screws.  
\*The figure shows an example of the installation holes facing the left. They can also be turned to face the right.



Space-saving mounting bracket  
OP-84260

Go to step 5. ▶

### I Mounting brackets for SL-VF/VH (All come 2 pcs. to 1 set)

Model	Product name
OP-83180	Standard mounting bracket J
OP-42347	Standard mounting bracket A
OP-42348	Standard mounting bracket B
OP-42349	Standard mounting bracket C
OP-51698	Slim mounting bracket
OP-42371	L-shaped mounting bracket
OP-83181	Compact E-to-E bracket
OP-42370	E-to-E bracket

### I Mounting brackets for SL-VHM (All come 2 pcs. to 1 set)

Model	Product name
OP-84259	Standard mounting bracket
OP-84260	Space-saving mounting bracket

## step 5 Select the cable

Select the cable appropriate for the connection method and necessary functions, and then use the cable specifications chart to select the cable with the correct output type (PNP/NPN) and length.

**Basic connection**

Safety light curtain (pp. 16-17)

Most simple standard pattern

Mounting bracket (pp. 18-19)

Connection cable A B

**Note** The connection cable is sold separately.

- Note**
- There are two types of cable: simple function type and multi-function type. The type of cable used determines the function that can be used. (The number of conductors is different from each other.) Therefore, the two types of cables cannot be mixed at the same time. Make sure to use the appropriate type of cable for your applications.
  - Cables with different output type cannot be combined. Be sure to match the PNP or NPN output type especially when using the unit connection cable (for extension use).
  - The minimum bending radius for the cable is 5 mm.

When a large number of functions are not necessary

### ▶ Simple function type cable for basic connection

- I 8-strand shielded cable, brown/blue: AWG24 (cross-section area: 0.22 mm<sup>2</sup>)
- I Other: AWG26 (cross-section area: 0.14 mm<sup>2</sup>)

#### A Unit connection cable

Select the length and output type.

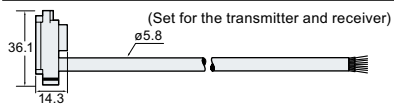
Shape	Output type	Length	Model
	PNP	7 m	SL-VP7P
		15 m	SL-VP15P
	NPN	7 m	SL-VP7N
		15 m	SL-VP15N

◎ The SL-V functions that can be used with the simple function type cable are limited. Check the functions in the "Available Functions" chart below.

When using all of the SL-V functions

### ▶ Multi-function type cable for basic connection

- I 12-strand shielded cable, brown/blue: AWG24 (cross-section area: 0.22 mm<sup>2</sup>)
- I Other: AWG26 (cross-section area: 0.14 mm<sup>2</sup>)

#### B Unit connection cable

Select the length and output type.

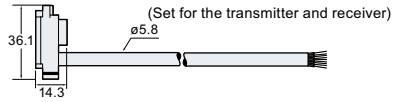
Shape	Output type	Length	Model
	PNP	7 m	SL-VP7PM
		15 m	SL-VP15PM
	NPN	7 m	SL-VP7NM
		15 m	SL-VP15NM

### Series connection

Safety light curtain (pp. 16-17)

Series connection cable C

**Cable rules**

Since up to 3 of the SL-V units can be connected in series, up to 2 sets of series connection cables are required. Two sets of the SL-VS10 (cable length :10 m) can be used. In this case, the sum of the length of all type of cables, including the series connection cable, must be 50 m or less. This limitation is also applicable to each transmitter and receiver respectively.

**Restrictions for series connection**

- Up to 3 units
- Up to 240 total number of beam axes

Required for series connection

### ▶ Series connection cable

#### C Series connection cable

Select the length.

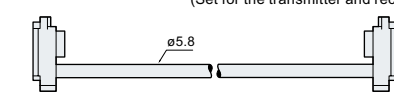
Shape	Length	Model
	0.08 m	SL-VS0
	0.15 m	SL-VS01
	0.5 m	SL-VS05
	1 m	SL-VS1
	3 m	SL-VS3
	10 m	SL-VS10

When using the SL-V dedicated relay terminal SL-T11R

### ▶ Cable for the SL-T11R

#### Unit connection cable

Select the length.

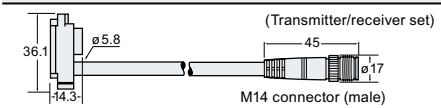
Shape	Length	Model
	3 m	SL-VPT3PM
	5 m	SL-VPT5PM
	10 m	SL-VPT10PM

#### Relay cable

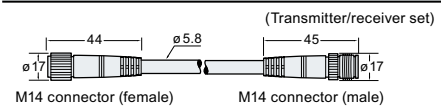
Shape	Length	Model
	10 m	SL-VCT10PM

### Extension connection

Safety light curtain (pp. 16-17)

Used when the length of basic connection is not enough

Mounting bracket (pp. 18-19)

Connection cable (for extension) **D H**

Relay cable **E I**

Extension cable **F J**

Male connector Female connector Male connector Female connector

**Cable rules** When using the connection cable, relay cable and extension cable together, the combined cable length for each the transmitter and receiver must be 30 m or less.

When a large number of functions are not necessary with an extension cable

## Simple function type cable for extension

- I 8-strand shielded cable, brown/blue: AWG24 (cross-section area: 0.22 mm<sup>2</sup>)
- I Other: AWG26 (cross-section area: 0.14 mm<sup>2</sup>)

©The SL-V functions that can be used with the simple function type cable are limited. See the "Available Functions" chart on page 31.

**D Connection cable (for extension)** Select the length and output type. Use in combination with the relay cable and extension cable.

Shape	Output type	Length	Model
<p>(Set for the transmitter and receiver)</p> <p>M12 connector (male)</p>	PNP	0.3 m	SL-VPC03P
		5 m	SL-VPC5P
	NPN	10 m	SL-VPC10P
		0.3 m	SL-VPC03N
		5 m	SL-VPC5N

**E Relay cable** Select the length and output type.

Shape	Output type	Length	Model
<p>(Set for the transmitter and receiver)</p> <p>M12 connector (female) M12 connector (male)</p>	PNP	10 m	SL-VCC10P
	NPN	10 m	SL-VCC10N

**F Extension cable** Select the length and output type.

Shape	Output type	Length	Model
<p>(Set for the transmitter and receiver)</p> <p>M12 connector (female)</p>	PNP	5 m	SL-VC5P
		10 m	SL-VC10P
	NPN	5 m	SL-VC5N
		10 m	SL-VC10N

When using all of the SL-V functions with an extension cable

## Multi-function type cable for extension

- I 12-strand shielded cable, brown/blue: AWG24 (cross-section area: 0.22 mm<sup>2</sup>)
- I Other: AWG26 (cross-section area: 0.14 mm<sup>2</sup>)

**H Connection cable (for extension)** Select the length and output type. Use in combination with the relay cable and extension cable.

Shape	Output type	Length	Model
<p>(Set for the transmitter and receiver)</p> <p>M14 connector (male)</p>	PNP	0.3 m	SL-VPC03PM
		5 m	SL-VPC5PM
	NPN	10 m	SL-VPC10PM
		0.3 m	SL-VPC03NM
		5 m	SL-VPC5NM

**I Relay cable** Select the length and output type.

Shape	Output type	Length	Model
<p>(Set for the transmitter and receiver)</p> <p>M14 connector (female) M14 connector (male)</p>	PNP	10 m	SL-VCC10PM
	NPN	10 m	SL-VCC10NM

**J Extension cable** Select the length and output type.

Shape	Output type	Length	Model
<p>(Set for the transmitter and receiver)</p> <p>M14 connector (female)</p>	PNP	5 m	SL-VC5PM
		10 m	SL-VC10PM
	NPN	5 m	SL-VC5NM
		10 m	SL-VC10NM

If optional protection is needed, go to step 6. ▶

If optional protection is not needed, the selection process ends here.

**step 6** Select the protection options as necessary

When necessary, add on the protection bar\* used to protect the safety light curtain from shock or the front protection cover used to protect the detection surface. \*This cannot be used with the tough, water-proof type SL-VFM/VHM.

For SL-VF/VH **Protect the safety light curtain from shock from the workpiece**

**▶ Slim type protection bar**



This can be used on all models except for SL-VHM. Select the specific protection bar model from the specification chart below according to the SL-V model selected in step 3.

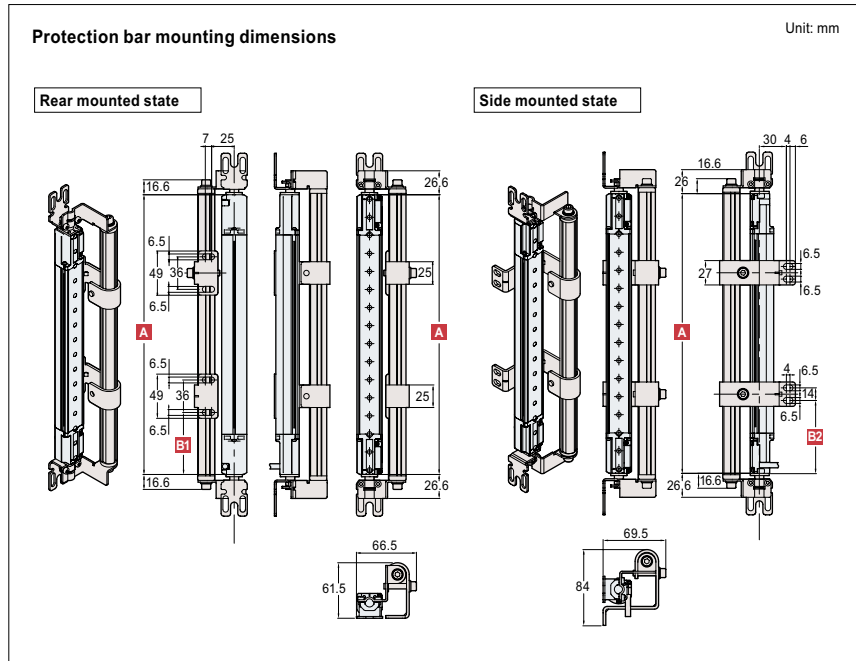

Select the model according to the SL-V model selected in step 3.

Unit: mm

Protection bar model	Corresponding SL-V model		No. of required intermediate support brackets for the protection bar	A SL-V length	B1 Mounting position for intermediate support brackets for the protection bar in case of rear mounting			B2 Mounting position for intermediate support brackets for the protection bar in case of side mounting								
	Beam axis pitch: 10 mm	Beam axis pitch: 20 mm			1st	2nd	3rd	1st	2nd	3rd						
SL-JB15	—	SL-V08H	0	150	Not required	Not required	Not required	Not required	Not required	Not required						
SL-JB23	SL-V23F	SL-V12H		230												
SL-JB31	SL-V31F	SL-V16H		310												
SL-JB39	SL-V39F	SL-V20H		390												
SL-JB47	SL-V47F	SL-V24H		470												
SL-JB55	SL-V55F	SL-V28H		550												
SL-JB63	SL-V63F	SL-V32H		630												
SL-JB71	SL-V71F	SL-V36H		710							340±20	Not required	Not required	350±20	Not required	Not required
SL-JB79	SL-V79F	SL-V40H		790							380±20			390±20		
SL-JB87	SL-V87F	SL-V44H		870							420±20			430±20		
SL-JB95	SL-V95F	SL-V48H	950	460±20	470±20											
SL-JB103	SL-V103F	SL-V52H	1030	500±20	510±20											
SL-JB111	SL-V111F	SL-V56H	1110	540±20	550±20											
SL-JB119	SL-V119F	SL-V60H	1190	580±20	590±20											
SL-JB127	SL-V127F	SL-V64H	1270	620±20	630±20											
SL-JB143	—	SL-V72H	1430	460±20	940±20	470±20	950±20									
SL-JB159	—	SL-V80H	1590	510±20	1040±20	520±20	1050±20									
SL-JB175	—	SL-V88H	1750	570±20	1150±20	580±20	1160±20									
SL-JB191	—	SL-V96H	1910	620±20	1260±20	630±20	1270±20									
SL-JB207	—	SL-V104H	2070	500±20	1020±20	1530±20	510±20	1030±20	1550±20							
SL-JB223	—	SL-V112H	2230	540±20	1100±20	1650±20	550±20	1110±20	1670±20							
SL-JB239	—	SL-V120H	2390	580±20	1180±20	1770±20	590±20	1190±20	1790±20							

**Note**

● Two sets are required to install the protection bar on both the transmitter and receiver. ● When installing the protection bar to SL-V, either the standard bracket A (OP-42347), B (OP-42348), C (OP-42349) or J (OP-83180) is required. ● The protection bar and standard mounting brackets are secured with hexagonal-socket bolts, so the angle cannot be adjusted between the mounting brackets and protection bars. However, the angle between the SL-V and mounting brackets can be adjusted in order to adjust the beam axes. ● The protection bar can be mounted to the rear or side of the SL-V. Select the appropriate intermediate support bracket according to the type of mounting. ● Mount the SL-V within the angle shown to the right in order to prevent the SL-V beam axes from being cut off by the protection bar or intermediate support bracket.

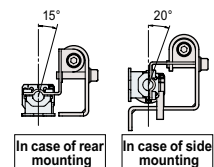

**Note** The optional protections are sold separately.

For SL-VF/VH **Protect the detection surface**

## ▶ Slim type front protection cover

☑ Select the model according to the SL-V model selected in step 3.



Select the model from the chart to the right according to the SL-V model selected in step 3.

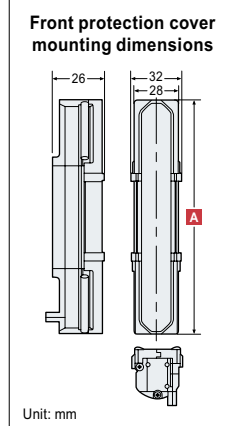

\* Two sets are required to install the protection bar on both the transmitter and receiver. The dimmer filter is used attached to the front protection cover. Refer to the detection distances in the chart on the right when using the dimmer filter.

\* The L-shaped mounting bracket (OP-42371) cannot be used when the front protection cover is attached.

Front protection cover model	Corresponding SL-V model		Dimmer filter model	A Length (mm)
	Beam axis pitch: 10 mm	Beam axis pitch: 20 mm		
OP-51454	—	SL-V08H	OP-51469	150.3
OP-51455	SL-V23F	SL-V12H	—	230.3
OP-51456	SL-V31F	SL-V16H	OP-51470	310.3
OP-51457	SL-V39F	SL-V20H	—	390.3
OP-51458	SL-V47F	SL-V24H	OP-51471	470.3
OP-51459	SL-V55F	SL-V28H	—	550.3
OP-51460	SL-V63F	SL-V32H	OP-51472	630.3
OP-51461	SL-V71F	SL-V36H	—	710.3
OP-51462	SL-V79F	SL-V40H		790.3
OP-51463	SL-V87F	SL-V44H		870.3
OP-51464	SL-V95F	SL-V48H	OP-51473	950.3
OP-51465	SL-V103F	SL-V52H	—	1030.3
OP-51466	SL-V111F	SL-V56H		1110.3
OP-51467	SL-V119F	SL-V60H		1190.3
OP-51468	SL-V127F	SL-V64H	OP-51474	1270.3
OP-83198	—	SL-V72H	—	1430.2
OP-83200	—	SL-V80H		1590.2
OP-83202	—	SL-V88H		1750.2
OP-83204	—	SL-V96H	—	1910.2
OP-83206	—	SL-V104H		2070.2
OP-83208	—	SL-V112H		2230.2
OP-83210	—	SL-V120H	—	2390.2

For SL-VFM/VHM **Protect the detection surface for the tough, water-proof type**

## ▶ Tough, water-proof front protection cover

☑ Select the model according to the SL-V model selected in step 3.



\* Two sets are required to install the protection bar on both the transmitter and receiver. The dimmer filter is used attached to the front protection cover. Refer to the detection distances in the chart to the lower right when using the dimmer filter. When using the dimmer filter, use the standard mounting brackets (OP-84259). If the standard mounting bracket is not used, the dimmer filter may slide off from the front protection cover.

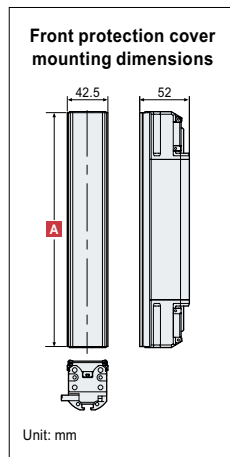

Front protection cover model	Corresponding SL-V model		Dimmer filter model	A Length (mm)
	Beam axis pitch: 10 mm	Beam axis pitch: 20 mm		
OP-84238	SL-V23FM	SL-V12HM	—	245
OP-84239	SL-V31FM	SL-V16HM		325
OP-84240	SL-V39FM	SL-V20HM		405
OP-84241	SL-V47FM	SL-V24HM	OP-84256	485
OP-84242	SL-V55FM	SL-V28HM	—	565
OP-84243	SL-V63FM	SL-V32HM		645
OP-84244	SL-V71FM	SL-V36HM		725
OP-84245	SL-V79FM	SL-V40HM	—	805
OP-84246	SL-V87FM	SL-V44HM		885
OP-84247	SL-V95FM	SL-V48HM		965
OP-84248	SL-V103FM	SL-V52HM	OP-84257	1045
OP-84249	SL-V111FM	SL-V56HM		1125
OP-84250	SL-V119FM	SL-V60HM		1205
OP-84251	SL-V127FM	SL-V64HM	—	1285
OP-84252	—	SL-V72HM		1444
OP-84253	—	SL-V80HM		1604
OP-84254	—	SL-V88HM	OP-84258	1764
OP-84255	—	SL-V96HM		1924

### Dimmer filter

When the dimmer filter is attached, the detection distance is decreased. See the chart to the right.

### Detection distance when using the dimmer filter

No. of front protection covers used	No. of dimmer filter used	SL-V Series detection distance (m)*1	
		Beam axis pitch: 10 mm	Beam axis pitch: 20 mm
0	0	0.1 to 9	0.1 to 7
	1	0.1 to 8.5	0.1 to 6.4
	2	0.1 to 6.5	0.1 to 4.7
1	0	0.1 to 5	0.1 to 3.5
	1	0.1 to 5	0.1 to 3.5
	2	0.1 to 5	0.1 to 3.5
	3	0.1 to 5	0.1 to 3.5
	4	0.1 to 5	0.1 to 3.5
2	0	0.1 to 8	0.1 to 5.8
	1	0.1 to 6	0.1 to 4.3
	2	0.1 to 4.5	0.1 to 3.2
	3	0.1 to 3.5	0.1 to 2.4
	4	0.1 to 2.5	0.1 to 1.8

\*1. The detection distance varies according to the model.

**step 7 Select the controllers and power sources if necessary**

Select controllers and power sources for applications where relays and simplified wiring are needed or a controller to allow integration of other safety devices.

The following devices help you easily establish a Category 4 compatible safety circuit.

**▶ Type 4 Safety Relay Terminal dedicated for SL-V [SL-T11R]  
Power source dedicated for a Type 4 light curtain  
(with class 2 output) [SL-U2]**



Safety Relay Terminal dedicated for the SL-V

Model	Description	Safety input	Safety output	Other I/O
		Safety light curtain		
SL-T11R	Safety Relay Terminal dedicated for SL-V	1 ch (dedicated for SL-V)	1 ch (2 terminals)	EDM input, muting input, AUX output, muting lamp output, etc.

Power Source dedicated for Safety Light Curtain

System	Model	Description	Input power supply voltage	Output voltage	Output capacity	Power consumption
Switching type	SL-U2	Power supply dedicated for safety light curtain	100 to 240 VAC ±10% (50/60 Hz)	24 VDC ±10%, Class 2	1.8 A	135 VA

**step 8 Select the PC configuration software as necessary**

The SL-VH1S Makes It Possible to Reduce The On-Site Installation Time!

**▶ PC configuration software**



Model	Name
SL-V1UB	SL-V Ver.3 Configuration Software Interface Unit (USB cable included with the SL-V1UB)
SL-VH1S	SL-V Ver.3 Configuration Software

(Include with the SL-V1UB)

## Specifications (common)

Model	SL-VF/SL-VFM	SL-VH/SL-VHM	
Beam axis spacing/Lens diameter	10 mm/ø4 mm	20 mm/ø5 mm	
Detection capability	ø14 mm	ø25 mm	
Operating distance	0.1 m to 7.0 m	0.1 m to 9.0 m (detection height of 1,260 mm or less) 0.1 m to 7.0 m (detection height of 1,400 mm or more)	
Effective aperture angle	Max. ±2.5° (When operating distance is 3 m or more)		
Response time	7 to 23.4 ms (See "Response Time" (p. 10) for details.)		
Light source	Infrared LED (850 nm)		
Operation form	Turns on when no interruptions are present in the detection zone (excluding when the muting function is used)		
Rating	<b>Power voltage</b> 24 VDC +10%, -20% (Ripple P-P 10% or less) <b>Output</b> 2 outputs each for PNP and NPN. Can be changed by using the connector cable. <b>Max. load current</b> 500 mA <sup>*1</sup> <b>Residual voltage (during ON)</b> Max. 2.5 V (with a cable length of 7 m) <b>Leakage current</b> Max. 100 µA <sup>*2</sup> <b>Max. capacitive load</b> 2.2 µF (with a load resistance of 100 Ω) <b>Load wiring resistance</b> Max. 2.5 Ω <sup>*3</sup>		
OSSD	AUX		
	Interlock-reset-ready output		
	Alarm output		
	Clear/blocked output		
	State information output 1, 2		
Non safety-related output	Muting lamp output		
	EDM input		
	Wait input		
	Reset input		
	Muting input 1, 2		
Input	Override input		
	Protection circuit		
	Enclosure rating		
	Overvoltage category		
	Ambient temperature		
Environmental condition	Storage ambient temperature		
	Relative humidity		
	Storage relative humidity		
	Ambient light		
	Vibration		
	Shock		
	Material	Main unit case	
		Upper case/lower case	
		Front cover	
	Approved standards	EMC	EMS
Safety		EMI	
		IEC61496-1, EN61496-1, UL61496-1, IEC62061	
		EN55011 Class A, FCC Part15B Class A, ICES-003 Class A	
		IEC61496-1, EN61496-1, UL61496-1 (Type 4 ESPE)	
		IEC61496-2, UL61496-2, EN61496-2 (Type 4 AOPD)	
		IEC61508 (SIL3), EN61508 (SIL3), IEC62061 (SIL3), EN ISO13849-1 (Category 4, PL e)	
UL508			
UL1998			

\*1. When used in ambient temperatures between 45 to 55°C, the maximum should not exceed 300 mA.

\*2. Applies to situations when power is either off or disconnected.

\*3. The wiring resistance between the OSSD output and the connected equipment (excluding the resistance of the cable) must be 2.5 Ω or less to ensure operations. If using the NPN output with a cable length of 15 m or longer, and the load current consumption is 200 mA or more, the wire resistance must be 1.0 Ω or less.

\*4. When used under ambient temperature between 45 to 55°C, use incandescent lamps (24 VDC, 1 to 3 W) or LED lamps (load current: 10 to 100 mA).

## Meaning of Indicators

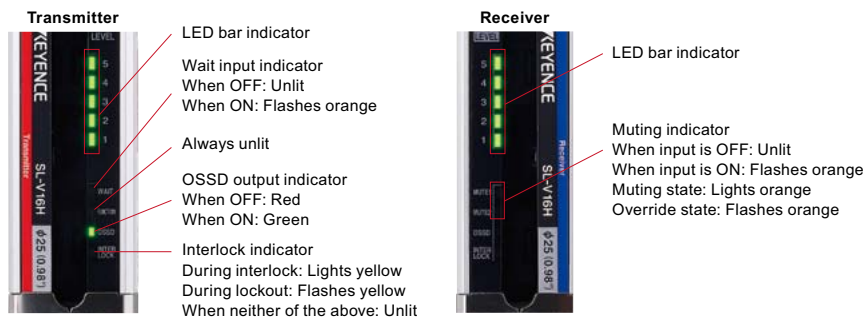

### LED bar indicator lights (During normal state)

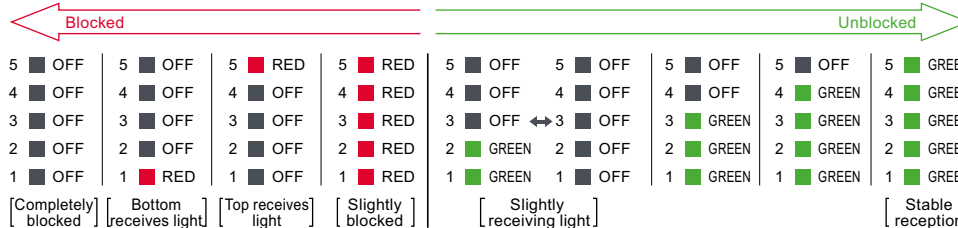

### During an error

Lit No. (Either transmitter or receiver) and the error	Error
2	OSSD error
1 and 2	EDM error
3	Communication error
1 and 3	Receiver error
2 and 3	Transmitter error
4	Interlock error
1 and 4	System error

\*For details, see the SL-V Operation Manual.

## Response time (OSSD output)

Unit: ms

Model	Response time (OSSD)	
	ON → OFF	OFF → ON*
SL-V23F/FM	9.1	49.1
SL-V31F/FM	10.2	50.2
SL-V39F/FM	11.3	51.3
SL-V47F/FM	12.4	52.4
SL-V55F/FM	13.5	53.5
SL-V63F/FM	14.6	54.6
SL-V71F/FM	15.7	55.7
SL-V79F/FM	16.8	56.8
SL-V87F/FM	17.9	57.9
SL-V95F/FM	19	59
SL-V103F/FM	20.1	60.1
SL-V111F/FM	21.2	61.2
SL-V119F/FM	22.3	62.3
SL-V127F/FM	23.4	63.4

\*If the interruption is present in the detection zone for less than 80 ms, the response time (OFF to ON) is to be 80 ms or more to ensure that the OSSD keeps OFF state for more than 80 ms.

### Note

When connecting the SL-V units in series, the response time (ON to OFF) is the sum of the response times of all the individual SL-V units, but the response time (OFF to ON) is the same as that of a single SL-V unit.

When connecting the SL-V32H (32 beam axes), SL-V24H (24 beam axes), and SL-V12L (12 beam axes) in series, the response time of each unit is 10.3 ms, 9.2 ms, and 7.6 ms respectively, and the response time (ON to OFF) is 10.3 ms + 9.2 ms + 7.6 ms = 27.1 ms. The response time (OFF to ON) is 27.1 ms + 40 ms = 67.1 ms.

Unit: ms

Model	Response time (OSSD)	
	ON → OFF	OFF → ON*
SL-V08H	7	47
SL-V12H/HM	7.6	47.6
SL-V16H/HM	8.1	48.1
SL-V20H/HM	8.7	48.7
SL-V24H/HM	9.2	49.2
SL-V28H/HM	9.8	49.8
SL-V32H/HM	10.3	50.3
SL-V36H/HM	10.9	50.9
SL-V40H/HM	11.4	51.4
SL-V44H/HM	12	52
SL-V48H/HM	12.5	52.5
SL-V52H/HM	13.1	53.1
SL-V56H/HM	13.6	53.6
SL-V60H/HM	14.2	54.2
SL-V64H/HM	14.7	54.7
SL-V72H/HM	15.8	55.8
SL-V80H/HM	16.9	56.9
SL-V88H/HM	18	58
SL-V96H/HM	19.1	59.1
SL-V104H	20.2	60.2
SL-V112H	21.3	61.3
SL-V120H	22.4	62.4

## Current consumption

Unit: mA

Model	When the centre indicator is ON		When the centre indicator is OFF	
	Transmitter	Receiver	Transmitter	Receiver
SL-V23F/FM	83	78	80	74
SL-V31F/FM	93	80	90	75
SL-V39F/FM	103	82	99	77
SL-V47F/FM	112	85	107	78
SL-V55F/FM	121	87	115	80
SL-V63F/FM	129	89	122	82
SL-V71F/FM	136	92	129	83
SL-V79F/FM	142	94	135	85
SL-V87F/FM	148	97	140	87
SL-V95F/FM	154	99	145	88
SL-V103F/FM	159	101	149	90
SL-V111F/FM	163	104	152	92
SL-V119F/FM	166	106	156	93
SL-V127F/FM	169	109	158	95

### Note

The current consumption of transmitter increase 10 mA and the one of receiver decrease 10 mA if the AUX output (red wire of the transmitter) and the EDM input (red wire of the receiver) are short-circuited and also the following additional condition is met. (The total consumption of both transmitter and receiver is fixed.)

- In case where PNP output type cable is used, the condition is that OSSD keeps OFF state.
- In case where NPN output type cable is used, the condition is that OSSD keeps ON state.

Unit: mA

Model	When the centre indicator is ON		When the centre indicator is OFF	
	Transmitter	Receiver	Transmitter	Receiver
SL-V08H	56	70	52	65
SL-V12H/HM	63	72	58	66
SL-V16H/HM	69	74	64	67
SL-V20H/HM	75	75	70	68
SL-V24H/HM	81	77	76	69
SL-V28H/HM	87	79	81	69
SL-V32H/HM	93	80	86	70
SL-V36H/HM	98	82	91	71
SL-V40H/HM	103	84	96	72
SL-V44H/HM	108	85	100	73
SL-V48H/HM	113	87	104	74
SL-V52H/HM	117	88	109	74
SL-V56H/HM	122	90	112	75
SL-V60H/HM	126	91	116	76
SL-V64H/HM	130	93	120	77
SL-V72H/HM	137	96	126	78
SL-V80H/HM	144	98	132	80
SL-V88H/HM	149	101	136	81
SL-V96H/HM	154	104	140	83
SL-V104H	159	107	143	84
SL-V112H	162	109	146	86
SL-V120H	165	112	147	87

## Weight

Unit: g

Model	Weight	
	Transmitter	Receiver
SL-V23F	200	205
SL-V31F	270	275
SL-V39F	330	345
SL-V47F	390	405
SL-V55F	450	465
SL-V63F	510	525
SL-V71F	570	585
SL-V79F	620	635
SL-V87F	670	685
SL-V95F	720	735
SL-V103F	760	775
SL-V111F	810	815
SL-V119F	850	855
SL-V127F	890	895

Unit: g

Model	Weight	
	Transmitter	Receiver
SL-V23FM	670	680
SL-V31FM	830	840
SL-V39FM	990	1000
SL-V47FM	1150	1160
SL-V55FM	1300	1320
SL-V63FM	1460	1470
SL-V71FM	1610	1630
SL-V79FM	1760	1770
SL-V87FM	1900	1910
SL-V95FM	2050	2060
SL-V103FM	2190	2200
SL-V111FM	2330	2330
SL-V119FM	2470	2460
SL-V127FM	2590	2600

Unit: g

Model	Weight	
	Transmitter	Receiver
SL-V08H	150	155
SL-V12H	200	205
SL-V16H	250	265
SL-V20H	300	315
SL-V24H	350	365
SL-V28H	400	415
SL-V32H	450	465
SL-V36H	500	515
SL-V40H	550	575
SL-V44H	600	625
SL-V48H	650	675
SL-V52H	700	725
SL-V56H	750	775
SL-V60H	800	835
SL-V64H	860	885
SL-V72H	960	985
SL-V80H	1060	1095
SL-V88H	1160	1195
SL-V96H	1260	1295
SL-V104H	1360	1405
SL-V112H	1460	1505
SL-V120H	1570	1615

Unit: g

Model	Weight	
	Transmitter	Receiver
SL-V12HM	670	680
SL-V16HM	810	830
SL-V20HM	960	970
SL-V24HM	1110	1120
SL-V28HM	1250	1270
SL-V32HM	1400	1410
SL-V36HM	1540	1560
SL-V40HM	1690	1710
SL-V44HM	1830	1850
SL-V48HM	1980	2000
SL-V52HM	2130	2150
SL-V56HM	2270	2290
SL-V60HM	2420	2440
SL-V64HM	2560	2590
SL-V72HM	2850	2880
SL-V80HM	3140	3170
SL-V88HM	3440	3470
SL-V96HM	3730	3760

## Specifications [For SL-T11R/SL-U2]

Model		SL-T11R	
Combined light curtain		SL-V Series	
Response time FSD1, 2		ON to OFF: 6 ms OFF to ON: 15 ms	
Rating	Power voltage	24 VDC ±10% (Ripple P-P 10% or less)	
	Current consumption	100 mA or less (at 24VDC, SL-T11R alone)	
Output *	FSD1, 2	230 VAC, 4 A 30 VDC, 2 A (Resistance load)	
		230 VAC, 2 A (COS $\phi$ =0.3) (Inductive load)	
		30 VDC, 1 A (COS $\phi$ =0.3) (Inductive load)	
	Lifespan	Mechanical life: 10 million cycles or more Electrical life: 0.1 million cycles or more	
Environmental resistance	Enclosure rating	IP20 (IEC60529) Set inside the control panel with IP54 or more	
	Pollution degree	2	
	Overvoltage category	III (Relay load)	
	Ambient temperature	-10 to +55°C (No freezing)	
	Storage ambient temperature	-25 to +65°C (No freezing)	
	Relative humidity	15 to 85% RH (No condensation)	
	Storage relative humidity	15 to 95% RH (No condensation)	
	Vibration	10 to 55 Hz, 0.7 mm compound amplitude, 20 sweeps each in X, Y, and Z directions	
	Shock	100 m/s <sup>2</sup> (Approx. 10 G) 16 ms pulse, in X, Y, and Z directions 1,000 times each axis	
	Material	Polycarbonate	
Weight		Approx. 330 g	
Approved standards	EMC	EMS	UL61496-1, IEC61496-1, EN61496-1
		EMI	FCC Part15B Class A, ICES-003 Class A, EN55011 Class A
	Safety	UL61496-1, IEC61496-1, EN61496-1 (Type 4 ESPE), EN ISO13849-1:2008 (Category 4, PL <sub>e</sub> ), UL508	

\* For the specifications for the outputs other than FSD and for each input, refer to the SL-V Instruction Manual.

Model		SL-U2
System		Switching type
Input power supply voltage		100 to 240 VAC ±10% (50/60 Hz)
Overvoltage category		II
Output voltage		24 VDC ±10%, Class 2
Ripple/noise		240 mVp-p or less
Output capacity		1.8 A
Ambient temperature		-10 to +55°C (No freezing)
Relative humidity		35 to 85% RH (No condensation)
Pollution degree		2
Withstand voltage		1,500 VAC, 1 min. (between all external terminals and case)
Vibration resistance		10 to 55 Hz, double amplitude 0.7 mm, 20 sweeps each in X, Y, and Z directions
Shock resistance		100 m/s <sup>2</sup> (Approx. 10 G), 16 ms pulse, 1,000 iterations each in X, Y, and Z directions
Insulation resistance		At least 50 M $\Omega$ (500 VDC mega, between all external terminals and case)
Power consumption		135 VA
Supply voltage interruption		10 ms or less
Weight (excluding dedicated brackets)		Approx. 240 g
Approved standards	EMC	EN61000-6-2, EN55011 Class A, FCC Part15 Class A, ICES-003 Class A
	Safety	EN60950, EN50178, UL60950-1, UL508



## Example of wiring for the multi-function type cable

### PNP output

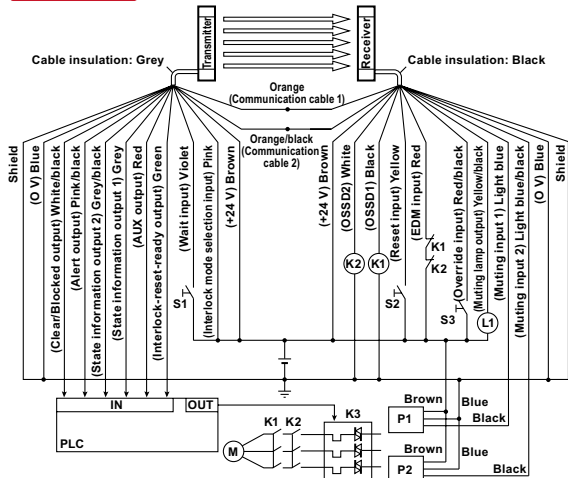

K1, K2: External device (Safety relay unit, magnet contactor, etc.)  
 K3: Solid state contactor\*1  
 S1: The switch for wait input (N.O.)\*1 Insulation on the violet wire is needed if this function is not used. (Open circuit : completely disconnected)  
 S2: The switch for reset input (N.O.)  
 S3: The switch for override input (N.O.)  
 L1: Muting lamp (Incandescent lamp or LED lamp)  
 P1, P2: Muting device (PZ self-contained photoelectric sensors <PNP output>, etc.)  
 M: 3-phase motor  
 PLC: For the monitoring use\*1  
 \*1. These are NON SAFETY-RELATED system.

**Note** ● The shielding wire of the PNP output type cable is connected to 0 V line in the SL-V. Do not connect the shielding wire to +24 V line.

### NPN output

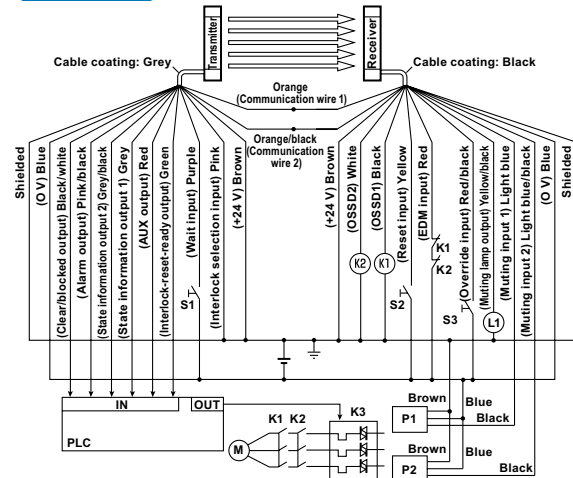

K1, K2 : External device (Safety relay unit, magnet contactor, etc.)  
 K3 : Solid state contactor\*1  
 S1 : The switch for wait input (N.O.)\*1 Insulation on the violet wire is needed if this function is not used. (Open circuit : completely disconnected)  
 S2 : The switch for reset input (N.O.)  
 S3 : The switch for override input (N.O.)  
 L1 : Muting lamp (Incandescent lamp or LED lamp)  
 P1, P2 : Muting device (PZ self-contained photoelectric sensors <NPN output>, etc.)  
 M : 3-phase motor  
 PLC : For the monitoring use\*1  
 \*1. These are NON SAFETY-RELATED system.

**Note** ● The shielding wire of the NPN output type cable is connected to +24 V line in the SL-V. Do not connect the shielding wire to 0 V line.

## I/O Circuit Diagram

### Overall circuit diagram Transmitter

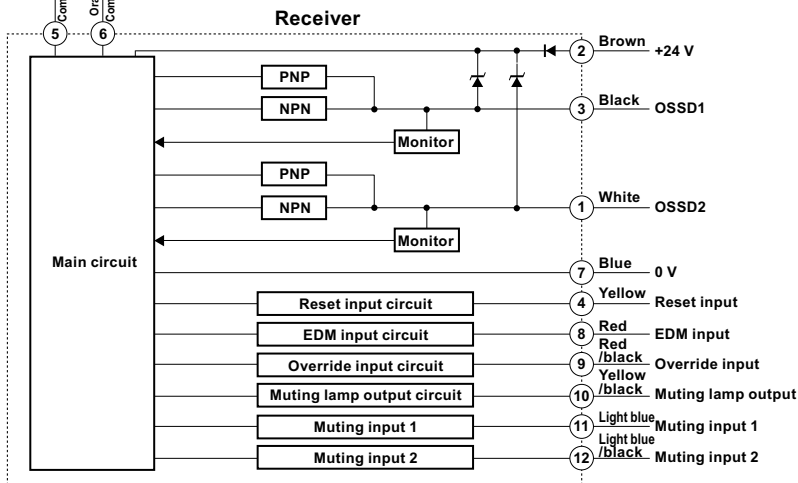
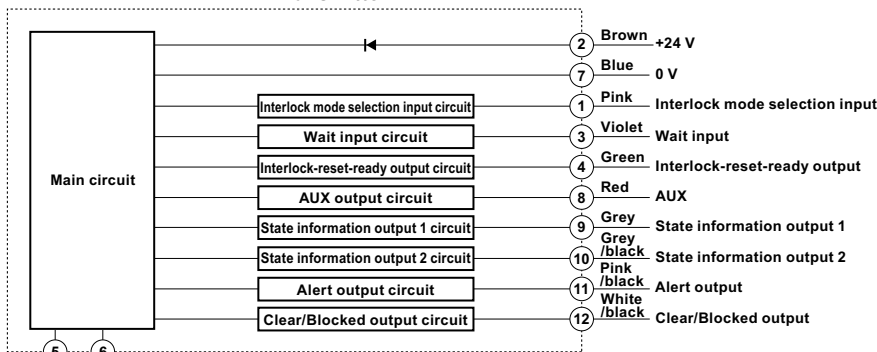

### OSSD PNP output circuit

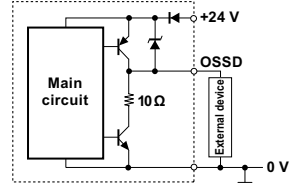

### OSSD NPN output circuit

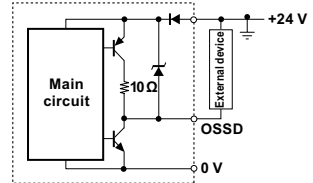

### Input circuit

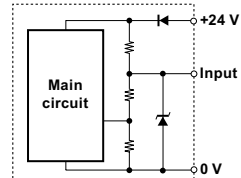

### Output circuit

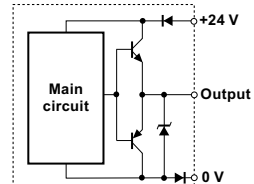

# Internal Circuit Diagram [For SL-T11R]

### Connector cable for receiver

Pin No.	Name
1	OSSD2
2	0 V
3	OSSD1
4	Reset input
5	Communication cable 1 (RS485+)
6	Communication cable 2 (RS485-)
7	+24 V
8	EDM input
9	Override input
10	Muting lamp output
11	Muting input 1
12	Muting input 2

### Connector cable for transmitter

Pin No.	Name
1	Interlock mode selection input
2	0 V
3	Wait input
4	Interlock-reset-ready output
5	Communication cable 1 (RS485+)
6	Communication cable 2 (RS485-)
7	+24 V
8	AUX (auxiliary) output
9	State information output 1
10	State information output 2
11	Alert output
12	Clear/blocked output

### Relay output terminal

Terminal No.	Name
1	FSD1
2	FSD2
3	FSD2
4	Function ground
5	0V
6	+24 V
7	EDM input
8	EDM input
9	EDM input

### Signal input/output terminal

Terminal No.	Name
10	Reset input
11	Reset input
12	+24 V
13	AUX (auxiliary) output
14	Muting lamp output
15	Clear/blocked output
16	Muting input 1
17	Muting input 2
18	Wait input
19	Override input
21	0 V

### Output connector A

Pin No.	Name
A-1	Interlock-reset-ready output
A-2	Alert output
A-3	0 V

### Output connector B

Pin No.	Name
B-1	AUX (auxiliary) output
B-2	State information output 1
B-3	State information output 2

\*For the internal circuit of the SL-V, refer to the SL-V Instruction Manual.

# Examples of wiring [For SL-T11R]

### Relay output terminal

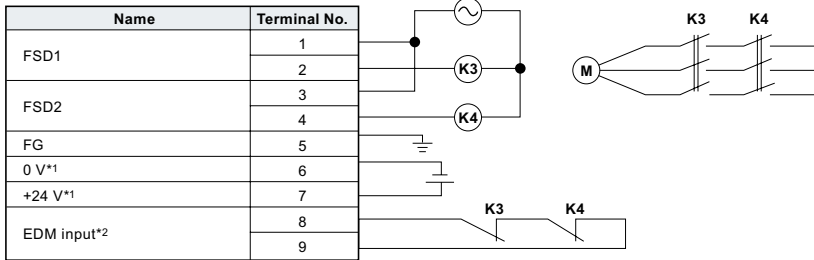

### Signal input/output terminal (In manual reset mode)

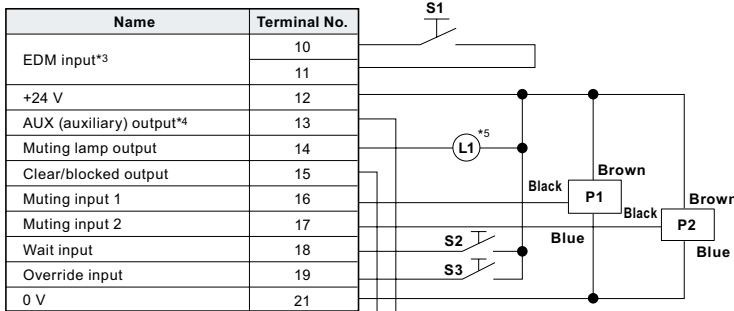

### Output connector A

Name	Pin No.
Interlock-reset-ready output	A-1
Alert output	A-2
0 V	A-3

### Output connector B

Name	Pin No.
AUX (auxiliary) output*	B-1
State information output 1	B-2
State information output 1	B-3

- K3, K4 : External device (Magnet contactor, etc.)
  - S1 : The switch for reset input (N.O.)
  - S2 : The switch for wait input (N.C.)
  - S3 : The switch for override input (N.O.)
  - L1 : Muting lamp (Incandescent lamp or LED lamp)
  - P1, P2 : Muting device (PZ self-contained photoelectric sensors <PNP output>, etc.)
  - M : 3-phase motor
  - PLC : For the monitoring use.
- This is a NON SAFETY-RELATED system.

S2 and PLC are NON SAFETY-RELATED systems.

- \*1. No. 6 and No. 7 do not need to be wired when the SL-U2 is connected.
- \*2. If it is not necessary to perform error detection for K3 and K4 (when EDM input is not used), keep the short bar between No. 8 and No. 9 connected.
- \*3. In the auto reset mode, keep the short bar between No. 10 and No. 11 connected. To release the lockout condition of the SL-V through the reset input, connect the N.C. switch.
- \*4. The AUX output operates in the same way for both the signal input/output terminal and the output connector B.
- \*5. For screw terminal 14 on the signal input/output terminal, the max load is 80mA. Because of this, a muting lamp must be connected to another power source if the rated power consumption is greater than 2W.

## Cable colours and pin positions

### Simple function type cable

For the transmitter		
Pin No.	Wire colour	Name
1	Pink	Interlock selection input
2	Brown	+24 V
3	Purple	Wait input
4	Green	Interlock-reset-ready output
5	Orange	Communication wire 1 (RS485_+)
6	Orange/black	Communication wire 2 (RS485_-)
7	Blue	0 V
8	Red	AUX (auxiliary) output

For the receiver		
Pin No.	Wire colour	Name
1	White	OSSD2
2	Brown	+24 V
3	Black	OSSD1
4	Yellow	Reset input
5	Orange	Communication wire 1 (RS485_+)
6	Orange/black	Communication wire 2 (RS485_-)
7	Blue	0 V
8	Red	EDM (external device monitor) input

**Note** M12 connector male pin position M12 connector female pin position



### Multi-function type cable

For the transmitter		
Pin No.	Wire colour	Name
1	Pink	Interlock selection input
2	Brown	+24 V
3	Purple	Wait input
4	Green	Interlock-reset-ready output
5	Orange	Communication wire 1 (RS485_+)
6	Orange/black	Communication wire 2 (RS485_-)
7	Blue	0 V
8	Red	AUX (auxiliary) output*1
9	Grey	State information output 1*1
10	Grey/black	State information output 2*1
11	Pink/black	Cleaning (alarm) output
12	Black/white	Clear/blocked output

For the receiver		
Pin No.	Wire colour	Name
1	White	OSSD2
2	Brown	+24 V
3	Black	OSSD1
4	Yellow	Reset input
5	Orange	Communication wire 1 (RS485_+)
6	Orange/black	Communication wire 2 (RS485_-)
7	Blue	0 V
8	Red	EDM (external device monitor) input
9	Red/white	Override input
10	Yellow/black	Muting lamp output
11	Lt. blue	Muting input 1
12	Lt. blue/black	Muting input 2

\*1. Various types of states can be alerted by using combinations of AUX output and state information outputs 1/2.  
For more information about simple mode, see the SL-V Operation Manual.

**Note** M14 connector male pin position M14 connector female pin position



## Available Functions Chart

Function name	Simple function type cable	Multi-function type cable
Self-diagnostic function	<input type="radio"/>	<input type="radio"/>
Series connection function	<input type="radio"/>	<input type="radio"/>
Interlock function	<input type="radio"/>	<input type="radio"/>
EDM function	<input type="radio"/>	<input type="radio"/>
Wait input	<input type="radio"/>	<input type="radio"/>
AUX (auxiliary) output	<input type="radio"/>	<input type="radio"/>
State information output	Cannot be used.	<input type="radio"/>
Cleaning (alert) output		<input type="radio"/>
Clear/blocked output		<input type="radio"/>
Muting Function		<input type="radio"/>
Override function		<input type="radio"/>
I/O monitoring function	<input type="radio"/>	<input type="radio"/>

## Precautions when selecting an input device (About OSSD output)

OSSD is safety-related control output. It connects to an external device (load), such as FSD or MPCE. The SL-V generates self-diagnosis signals on its internal control circuit to perform diagnoses to the output circuit (OSSD). These signals cause the OSSD to be periodically, forcibly and temporarily OFF state when no interruption exists in the detection zone.

The internal control circuit receives the feed-back signal (OFF signal) based on the self-diagnosis, the SL-V determines that its output circuit is in the normal operation. If this OFF signal is not returned to the internal control circuit, the SL-V determines that there is a problem in its output circuit or wiring and goes to the lockout condition.

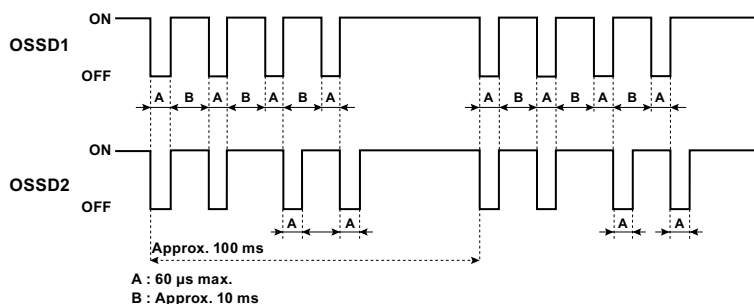

**Note** The equipment that do not respond to the temporary shutoff of the OSSD caused by the self-diagnostic signal must be used.

## Dimensions [For SL-VF/VH]



**SL-VF/VH  
Main unit**

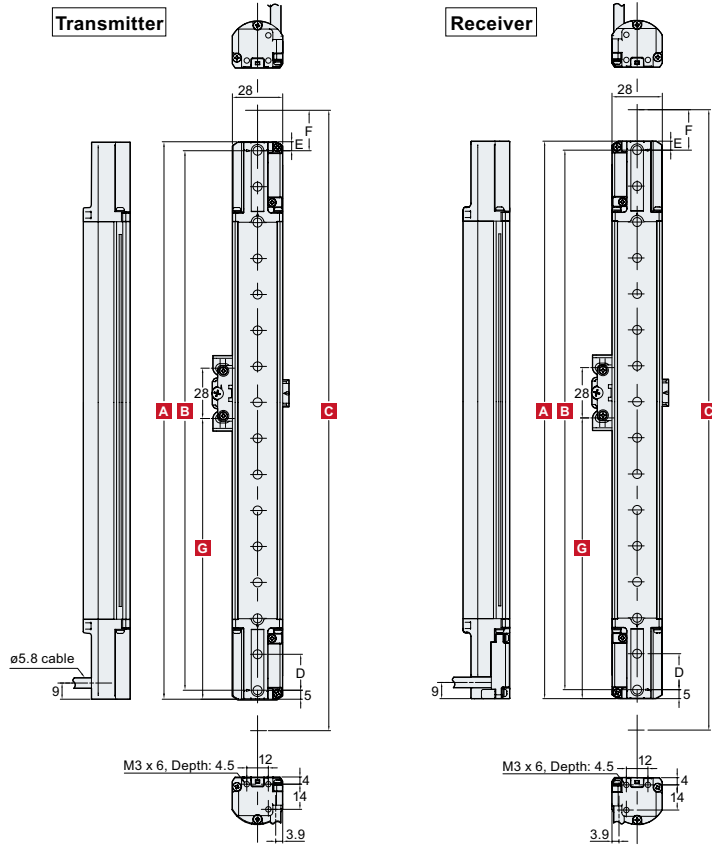

**Note**

If the length for a single SL-V unit is 710 mm or greater, use a compact E-to-E mounting bracket or an E-to-E mounting bracket additionally as an intermediate support bracket. The figures show an example for the use of one compact E-to-E bracket.

### Dimensions for units D – F

Series	D	E	F
SL-VF	10	5	12
SL-VH	20	5	22.5

### SL-VF unit variation

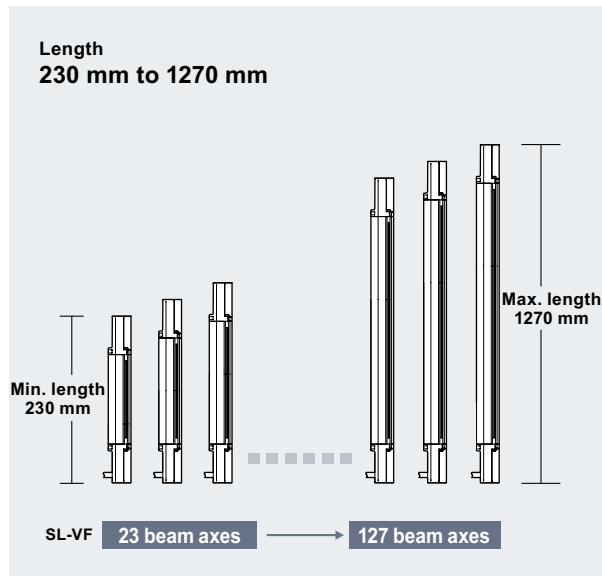

### SL-VH unit variation

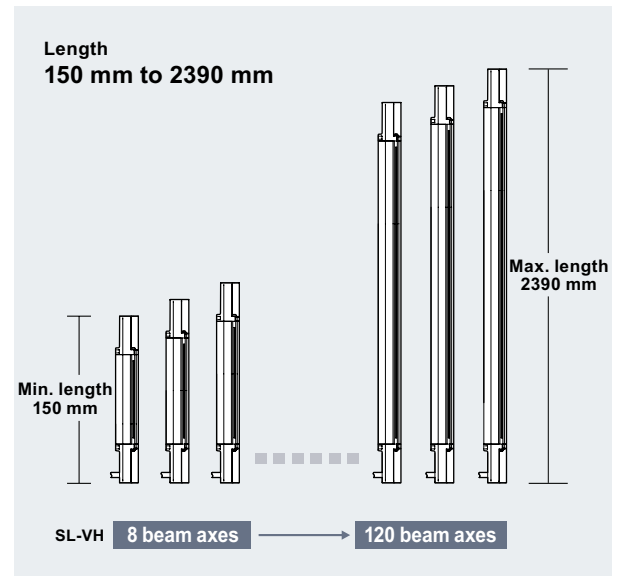

## Dimensions for units A – C

### SL-VF

Unit: mm

Model	A Length	No. of axes	B Detection height	C Protection height
SL-V23F	230	23	220	244
SL-V31F	310	31	300	324
SL-V39F	390	39	380	404
SL-V47F	470	47	460	484
SL-V55F	550	55	540	564
SL-V63F	630	63	620	644
SL-V71F	710	71	700	724
SL-V79F	790	79	780	804
SL-V87F	870	87	860	884
SL-V95F	950	95	940	964
SL-V103F	1030	103	1020	1044
SL-V111F	1110	111	1100	1124
SL-V119F	1190	119	1180	1204
SL-V127F	1270	127	1260	1284

### SL-VH

Unit: mm

Model	A Length	No. of axes	B Detection height	C Protection height
SL-V08H	150	8	140	185
SL-V12H	230	12	220	265
SL-V16H	310	16	300	345
SL-V20H	390	20	380	425
SL-V24H	470	24	460	505
SL-V28H	550	28	540	585
SL-V32H	630	32	620	665
SL-V36H	710	36	700	745
SL-V40H	790	40	780	825
SL-V44H	870	44	860	905
SL-V48H	950	48	940	985
SL-V52H	1030	52	1020	1065
SL-V56H	1110	56	1100	1145
SL-V60H	1190	60	1180	1225
SL-V64H	1270	64	1260	1305
SL-V72H	1430	72	1420	1465
SL-V80H	1590	80	1580	1625
SL-V88H	1750	88	1740	1785
SL-V96H	1910	96	1900	1945
SL-V104H	2070	104	2060	2105
SL-V112H	2230	112	2220	2265
SL-V120H	2390	120	2380	2425

## Mounting position G for the intermediate support bracket

When using a standard mounting bracket, slim bracket, or L-shaped bracket, if the total length is 710 mm or longer, a compact E-to-E mounting bracket is required as an intermediate support bracket. For the mounting position G of the compact E-to-E mounting bracket, see the lower chart below. When two or more intermediate support brackets are used, mount them so that the distance between the centres is within 600 mm in order to fulfill vibration and shock specifications.

### SL-VF/VH

Unit: mm

Model		G Intermediate support bracket mounting position				
F Series	H Series	1st	2nd	3rd	4th	
—	SL-V08H	Not required	Not required	Not required	Not required	
SL-V23F	SL-V12H					
SL-V31F	SL-V16H					
SL-V39F	SL-V20H					
SL-V47F	SL-V24H					
SL-V55F	SL-V28H					
SL-V63F	SL-V32H	340±50	Not required	Not required	Not required	
SL-V71F	SL-V36H					
SL-V79F	SL-V40H					
SL-V87F	SL-V44H					
SL-V95F	SL-V48H					
SL-V103F	SL-V52H					
SL-V111F	SL-V56H					
SL-V119F	SL-V60H					
SL-V127F	SL-V64H					
—	SL-V72H					460±100
—	SL-V80H	520±100	1050±100			
—	SL-V88H	420±100	860±100			
—	SL-V96H	460±100	940±100			
—	SL-V104H	500±100	1020±100			
—	SL-V112H	430±100	880±100			
—	SL-V120H	460±100	940±100	1420±100	1770±100	1900±100

## Mounting position G for the compact E-to-E mounting bracket

The following chart shows the bracket mounting position G and the number of brackets required. More intermediate support brackets are required as the unit becomes longer.

The compact E-to-E mounting brackets [OP-83181 or OP-42370] are sold separately and do not come with the safety light curtain. When three or more mounting brackets are used, mount them so that the distance between the centres is within 600 mm in order to fulfill vibration and shock specifications.

### SL-VF/VH

Unit: mm

Model		G Bracket mounting position						
F Series	H Series	1st	2nd	3rd	4th	5th	6th	
—	SL-V08H*1	60±10	Not required	Not required	Not required	Not required	Not required	
SL-V23F	SL-V12H	70±10	140±10					
SL-V31F	SL-V16H	70±10	220±10					
SL-V39F	SL-V20H	70±10	300±10					
SL-V47F	SL-V24H	70±10	380±10					
SL-V55F	SL-V28H	70±10	460±10					
SL-V63F	SL-V32H	70±10	540±10	620±20	Not required	Not required		
SL-V71F	SL-V36H	70±20	340±100					
SL-V79F	SL-V40H	70±20	380±100					
SL-V87F	SL-V44H	70±20	420±100					
SL-V95F	SL-V48H	70±20	460±100					
SL-V103F	SL-V52H	70±20	500±100					
SL-V111F	SL-V56H	70±20	540±100					
SL-V119F	SL-V60H	70±20	410±100					
SL-V127F	SL-V64H	70±20	440±100					
—	SL-V72H	70±20	490±100				750±100	1100±20
—	SL-V80H	70±20	540±100	810±100	1180±20			
—	SL-V88H	70±20	460±100	860±100	1260±100			
—	SL-V96H	70±20	500±100	940±100	1380±100			
—	SL-V104H	70±20	540±100	1020±100	1500±100			
—	SL-V112H	70±20	480±100	890±100	1310±100			
—	SL-V120H	70±20	510±100	960±100	1400±100	1850±100	2140±20	2300±20

\*1. Only one SL-V08H bracket can be installed.

# Dimensions [Mounting bracket]

## Standard mounting bracket J OP-83180

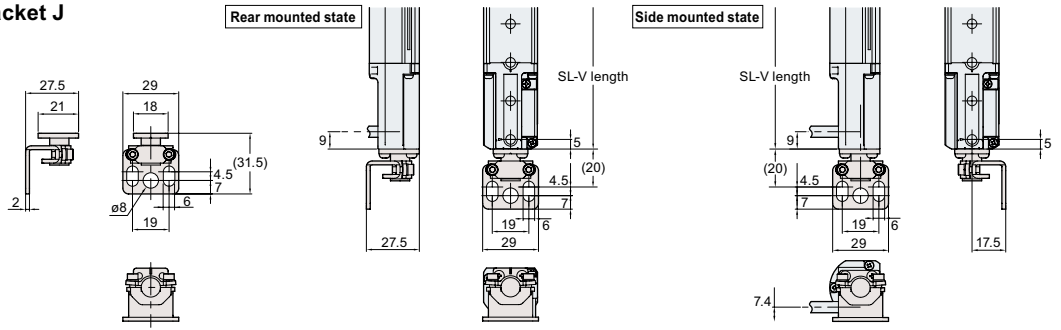

## Standard mounting bracket A OP-42347

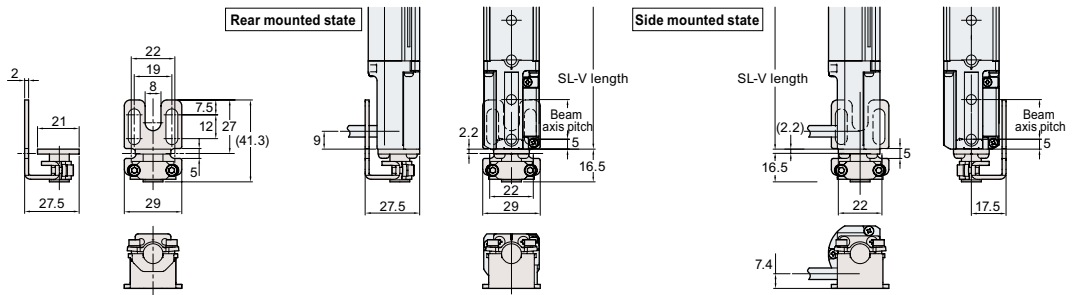
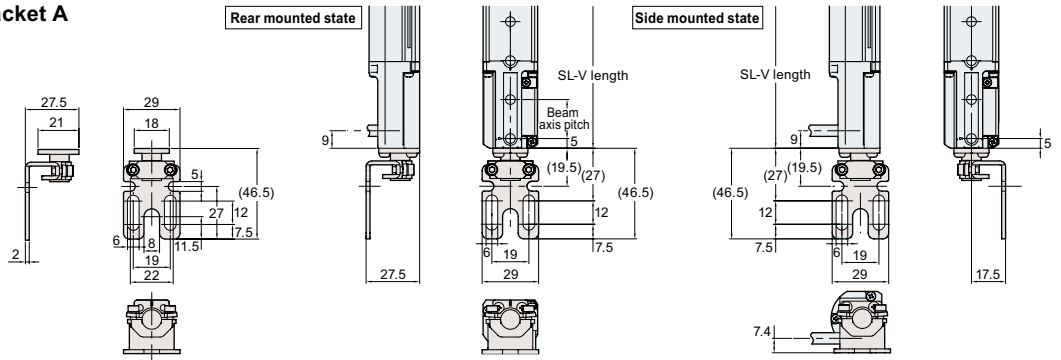
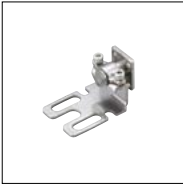

## Standard mounting bracket B OP-42348

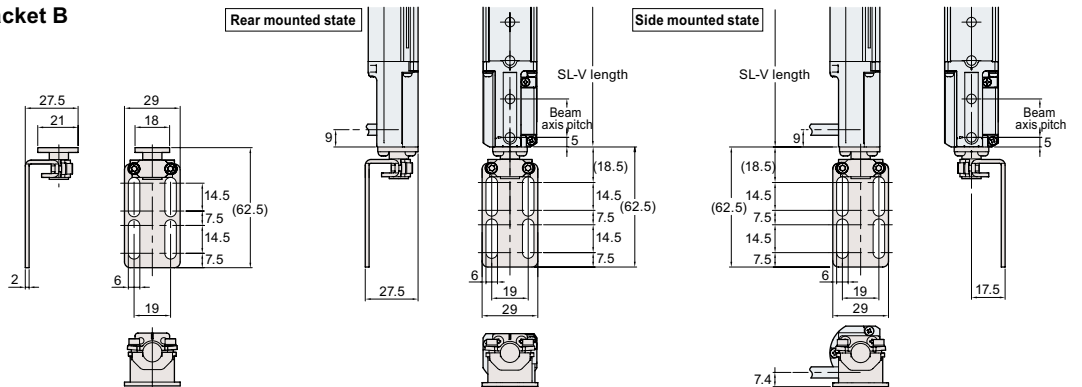

## Standard mounting bracket C OP-42349

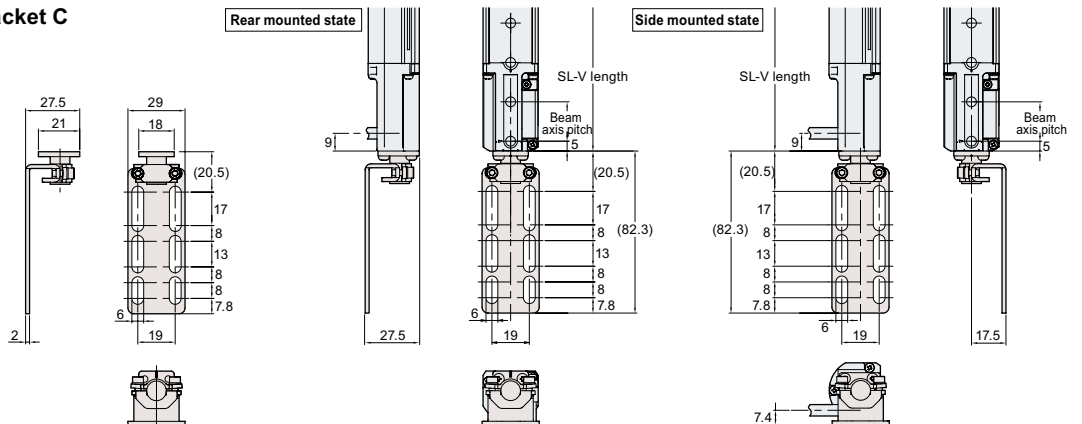
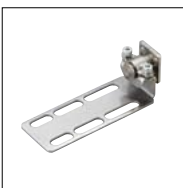

**Slim mounting bracket  
OP-51698**

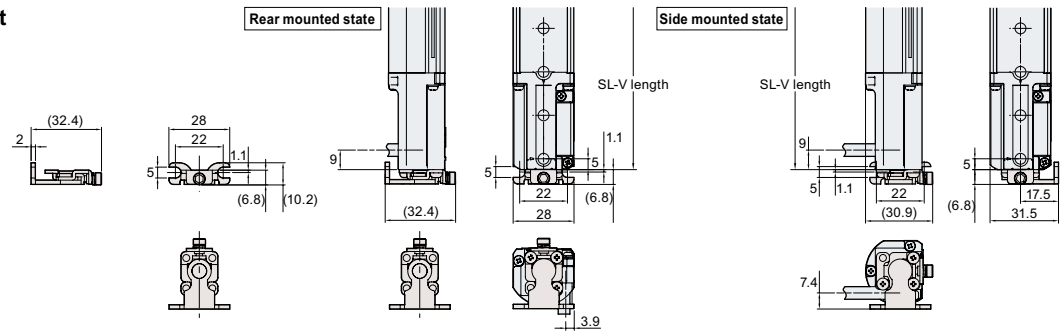

**L-shaped mounting bracket  
OP-42371**

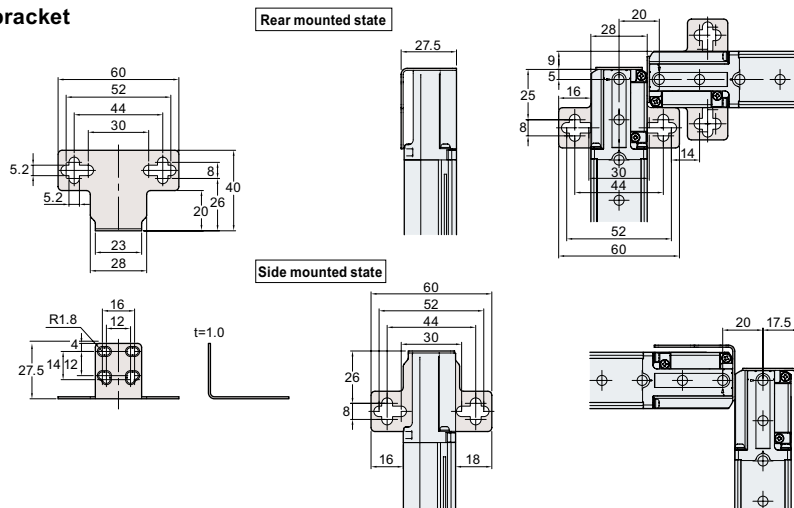

**Compact E-to-E bracket  
OP-83181**

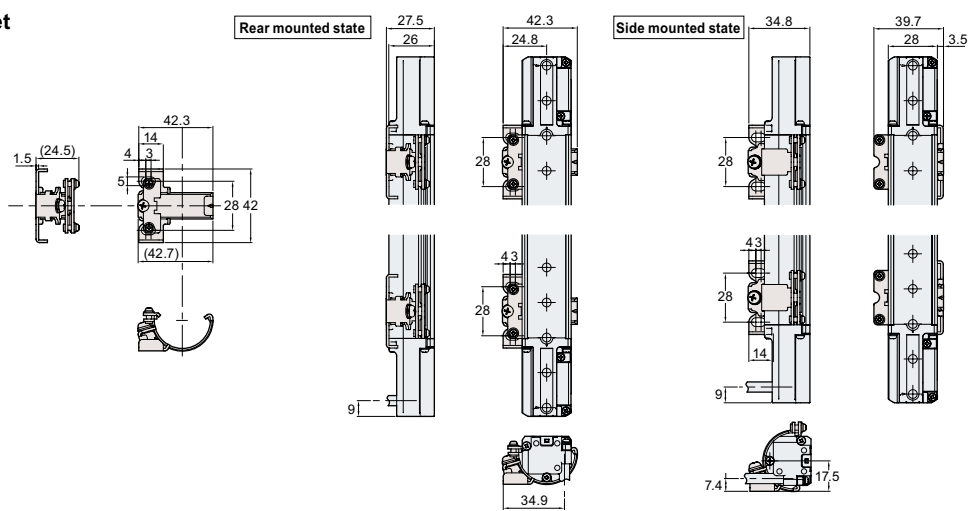

**E-to-E bracket  
OP-42370**

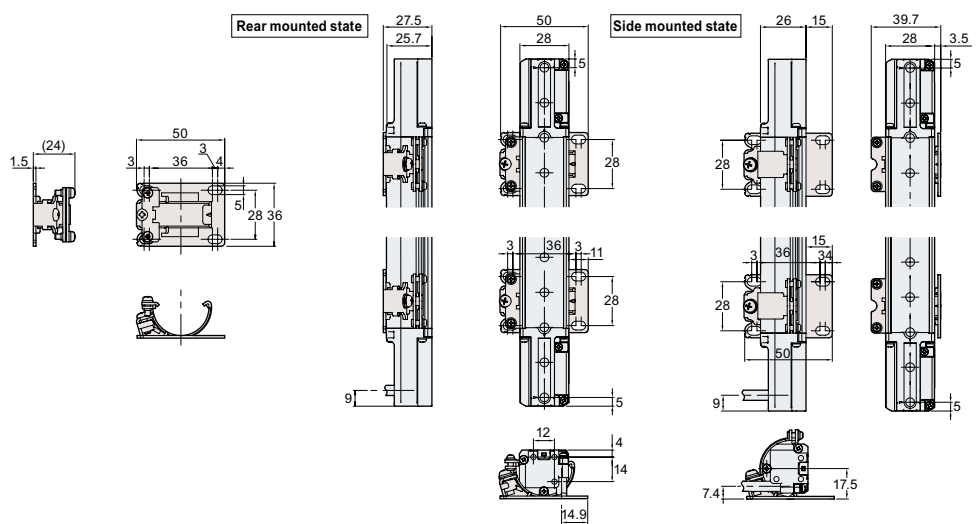

Dimensions [For SL-VFM/VHM]

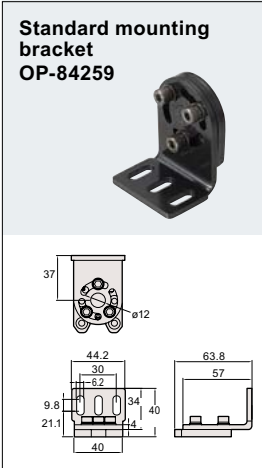

Rear mounted state  
**Transmitter**

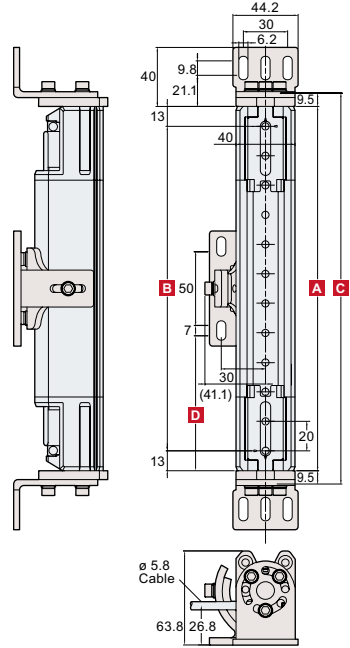

Rear mounted state  
**Receiver**

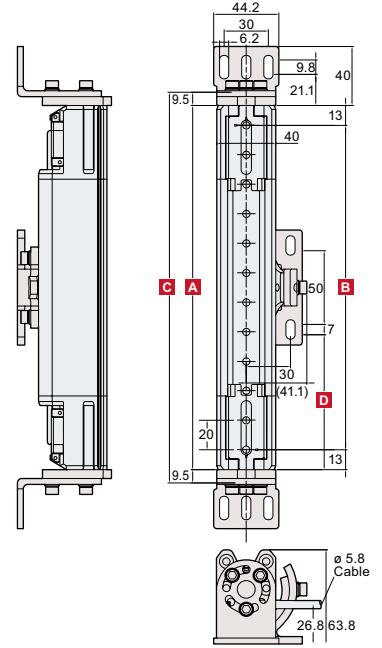

Side mounted state  
**Transmitter**

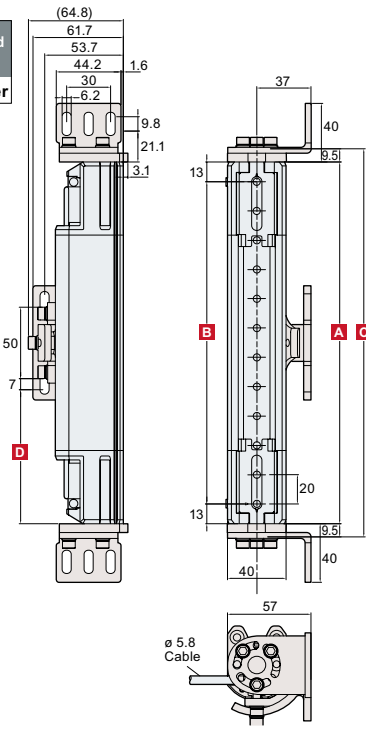

Side mounted state  
**Receiver**

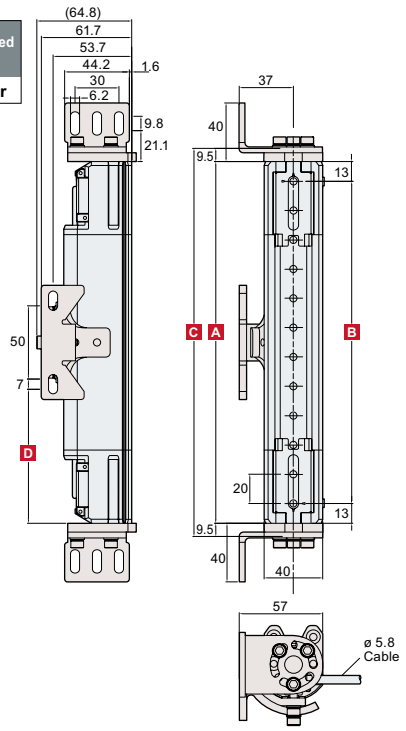

**When using a standard mounting bracket [For SL-VFM]**

Unit: mm

Model	No. of axes	A Length	B Detection height	C Protection height	D Space-saving mounting bracket mounting position (for intermediate support)			
					1st	2nd	3rd	
SL-V23FM	23	246	220	244	Not required	Not required	Not required	
SL-V31FM	31	326	300	324				
SL-V39FM	39	406	380	404				
SL-V47FM	47	486	460	484				
SL-V55FM	55	566	540	564				
SL-V63FM	63	646	620	644				
SL-V71FM	71	726	700	724				331±50
SL-V79FM	79	806	780	804				371±50
SL-V87FM	87	886	860	884				411±50
SL-V95FM	95	966	940	964				451±50
SL-V103FM	103	1046	1020	1044	317±50	666±50	Not required	
SL-V111FM	111	1126	1100	1124	344±50	719±50		
SL-V119FM	119	1206	1180	1204	370±50	772±50		
SL-V127FM	127	1286	1260	1284	397±50	826±50		

\*Space-saving brackets are required as intermediate support brackets as the unit becomes longer.

**When using a standard mounting bracket [For SL-VHM]**

Unit: mm

Model	No. of axes	A Length	B Detection height	C Protection height	D Space-saving mounting bracket mounting position (for intermediate support)			
					1st	2nd	3rd	
SL-V12HM	12	246	220	265	Not required	Not required	Not required	
SL-V16HM	16	326	300	345				
SL-V20HM	20	406	380	425				
SL-V24HM	24	486	460	505				
SL-V28HM	28	566	540	585				
SL-V32HM	32	646	620	665				
SL-V36HM	36	726	700	745				331±50
SL-V40HM	40	806	780	825				371±50
SL-V44HM	44	886	860	905				411±50
SL-V48HM	48	966	940	985				451±50
SL-V52HM	52	1046	1020	1065	317±50	666±50	Not required	
SL-V56HM	56	1126	1100	1145	344±50	719±50		
SL-V60HM	60	1206	1180	1225	370±50	772±50		
SL-V64HM	64	1286	1260	1305	397±50	826±50		
SL-V72HM	72	1446	1420	1465	330±50	691±50		1053±50
SL-V80HM	80	1606	1580	1625	370±50	771±50		1173±50
SL-V88HM	88	1766	1740	1785	410±50	851±50		1293±50
SL-V96HM	96	1926	1900	1945	450±50	931±50		1413±50

\*More space-saving brackets are required as intermediate support brackets as the unit becomes longer.

SL-VFM/VHM

[When using space-saving mounting brackets]



Space-saving mounting bracket  
OP-84260

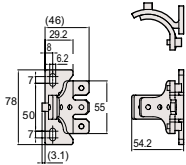

Rear mounted state  
Transmitter

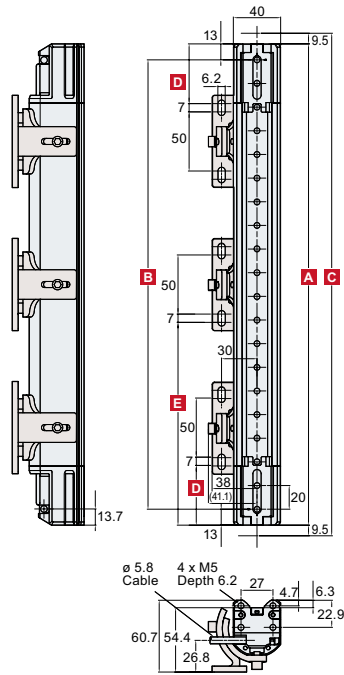

Rear mounted state  
Receiver

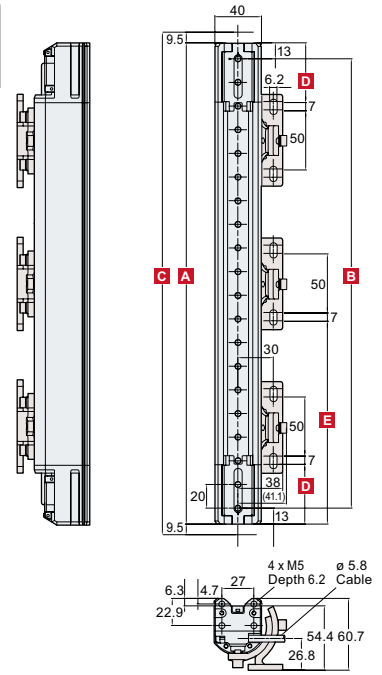

Side mounted state  
Transmitter

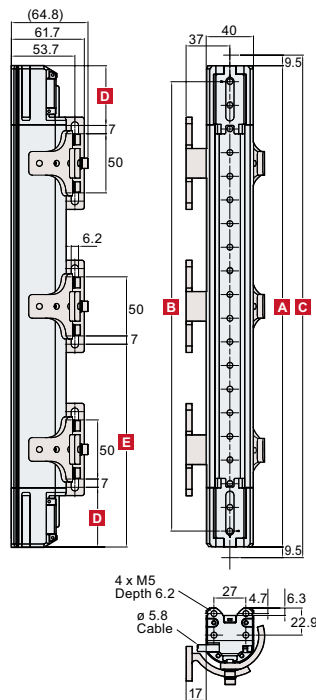

Side mounted state  
Receiver

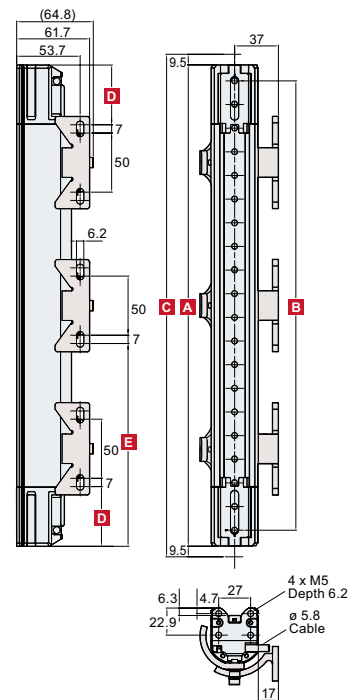

**When using space-saving mounting brackets [For SL-VFM]**

Unit: mm

Model	No. of axes	A Length	B Detection height	C Protection height	D Mounting position	E Mounting position (for intermediate support)		
						1st	2nd	3rd
SL-V23FM	23	246	220	244	60±20	Not required	Not required	Not required
SL-V31FM	31	326	300	324				
SL-V39FM	39	406	380	404				
SL-V47FM	47	486	460	484				
SL-V55FM	55	566	540	564		331±50	666±50	Not required
SL-V63FM	63	646	620	644		371±50		
SL-V71FM	71	726	700	724		411±50		
SL-V79FM	79	806	780	804		451±50		
SL-V87FM	87	886	860	884		317±50		
SL-V95FM	95	966	940	964		344±50		
SL-V103FM	103	1046	1020	1044		370±50		
SL-V111FM	111	1126	1100	1124		397±50		
SL-V119FM	119	1206	1180	1204				
SL-V127FM	127	1286	1260	1284				

\*Space-saving brackets are required as intermediate support brackets as the unit becomes longer.

**When using space-saving mounting brackets [For SL-VHM]**

Unit: mm

Model	No. of axes	A Length	B Detection height	C Protection height	D Mounting position	E Mounting position (for intermediate support)		
						1st	2nd	3rd
SL-V12HM	12	246	220	265	60±20	Not required	Not required	Not required
SL-V16HM	16	326	300	345				
SL-V20HM	20	406	380	425				
SL-V24HM	24	486	460	505				
SL-V28HM	28	566	540	585		331±50	666±50	Not required
SL-V32HM	32	646	620	665		371±50		
SL-V36HM	36	726	700	745		411±50		
SL-V40HM	40	806	780	825		451±50		
SL-V44HM	44	886	860	905		317±50		
SL-V48HM	48	966	940	985		344±50		
SL-V52HM	52	1046	1020	1065		370±50		
SL-V56HM	56	1126	1100	1145		397±50		
SL-V60HM	60	1206	1180	1225		330±50		
SL-V64HM	64	1286	1260	1305		370±50		
SL-V72HM	72	1446	1420	1465		410±50		
SL-V80HM	80	1606	1580	1625		450±50		
SL-V88HM	88	1766	1740	1785				
SL-V96HM	96	1926	1900	1945				

\*More space-saving brackets are required as intermediate support brackets as the unit becomes longer.

**SL-T11R**

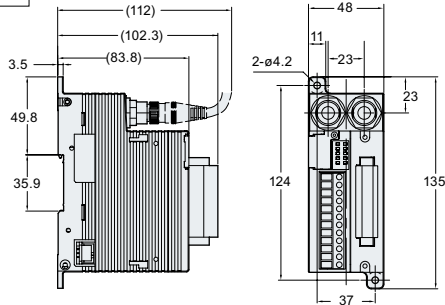

**SL-U2**

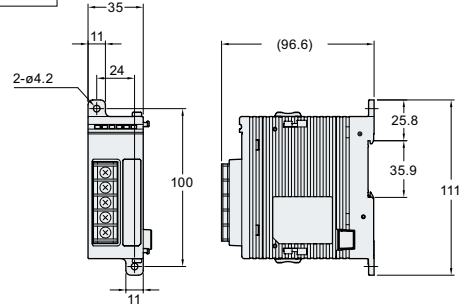

Please visit: [www.keyence.com](http://www.keyence.com)



**SAFETY INFORMATION**

Please read the instruction manual carefully in order to safely operate any KEYENCE product.

**GLOBAL NETWORK**

CONTACT YOUR NEAREST OFFICE FOR RELEASE STATUS.

**AUSTRIA**  
Phone: +43-2236-378266-0

**CZECH REPUBLIC**  
Phone: +420-222-191-483

**INDIA**  
Phone: +91-44-4963-0900

**MALAYSIA**  
Phone: +60-3-7883-2211

**SINGAPORE**  
Phone: +65-6392-1011

**THAILAND**  
Phone: +66-2-369-2777

**BELGIUM**  
Phone: +32-15-281-222

**FRANCE**  
Phone: +33-1-56-37-78-00

**INDONESIA**  
Phone: +62-21-2966-0120

**MEXICO**  
Phone: +52-55-8850-0100

**SLOVAKIA**  
Phone: +421-25939-6461

**UK & IRELAND**  
Phone: +44 (0) 1908-696-900

**BRAZIL**  
Phone: +55-11-3045-4011

**GERMANY**  
Phone: +49-6102-3689-0

**ITALY**  
Phone: +39-02-6688220

**NETHERLANDS**  
Phone: +31-40-20-66-100

**SLOVENIA**  
Phone: +386-1-4701-666

**USA**  
Phone: +1-201-930-0100

**CANADA**  
Phone: +1-905-366-7655

**HONG KONG**  
Phone: +852-3104-1010

**JAPAN**  
Phone: +81-6-6379-2211

**POLAND**  
Phone: +48-71-36861-60

**SWITZERLAND**  
Phone: +41-43-455-77-30

**VIETNAM**  
Phone: +84-4-3772-5555

**CHINA**  
Phone: +86-21-5058-6228

**HUNGARY**  
Phone: +36-1-802-73-60

**KOREA**  
Phone: +82-31-789-4300

**ROMANIA**  
Phone: +40-269-232-808

**TAIWAN**  
Phone: +886-2-2721-8080