

**Rotation speed monitor
single-channel
IM21-14-CDTRI**

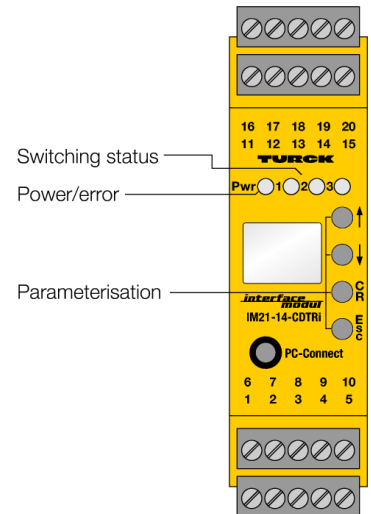
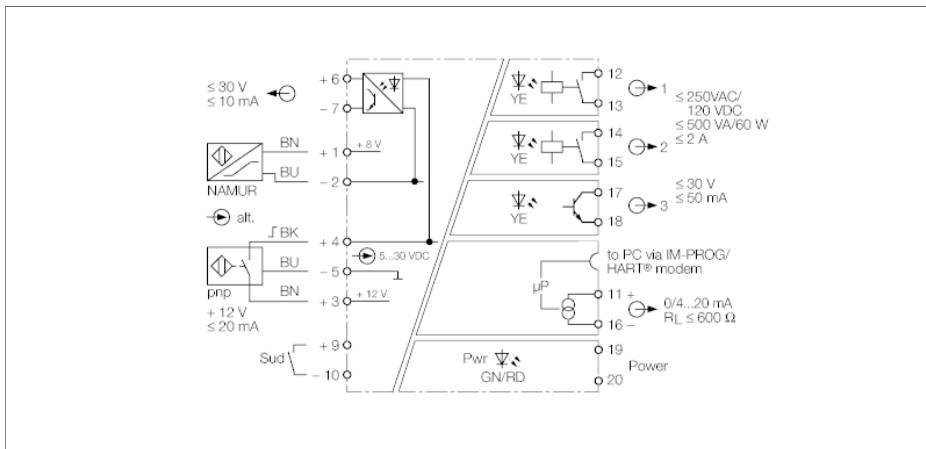

The rotation speed monitor IM21-14-CDTRI analyzes pulse frequencies, rotation speeds and pulse trains of rotating motor parts, gears or turbines and monitors them for overrange resp. underrange of adjusted limit values. A display integrated in the front cover indicates the current value.

The switching status of the corresponding output relay i.e. transistor is indicated by a yellow LED and operational readiness by a green LED. Input pulses are shown on the display. For signal detection, sensors acc. to EN 60947-5-6 (NAMUR), 3-wire pnp sensors or external signal sources with pulse levels of 5...30 VDC can be used. If NAMUR sensors are connected, the line is monitored according to wire-break and/or short-circuit depending on the setting. In case of input circuit errors the relays are de-energized, the transistor is inhibited and the Power-LED (Pwr) changes to red.

Three-wire pnp sensors can be supplied with 12 V (20 mA) by the rotation speed monitor. External signal sources must have a signal level of 5...30 VDC. The input pulse signal is transmitted to the potential-free pulse output and from there to further processing units.

In order to achieve short response times for all applications, low frequencies are monitored according to the principle of period duration measurement and high frequencies are monitored with a time window. In case of low frequencies, the response time depends only on the period duration of the signal. The device is parameterized via four pushbuttons. The parameters are shown on the display.

Each of the three outputs can be parameterized for *overspeed* or *underspeed* monitoring. Moreover, a *window function* can be parameterized, showing over and underspeed monitoring of both relay outputs. The transistor output can also be used as pulse divider. The measured value is permanently written to a ring buffer with up to 8000 measuring points. The writing process is stopped with a predefined trigger event, like for example the exceedance of a limit value. After that, the stored signal sequence can be read.

The switching hysteresis is defined by programming the switch-on and switch-off point. Additionally, output cut-off due to sudden frequency changes can be avoided if a switch-off delay is programmed for each output. A locking function prevents the output relay of being switched on again. The outputs are operated in NO mode; in "good-condition" the corresponding output is in switched state.

Rotation speed and limit value settings are displayed in Hz. The display and the settings can be adjusted to the required measuring unit by setting a time base and the number of pulses per rotation. For example, if min⁻¹ is selected, the time base has to be set to 60.

- **Rotation speed monitor**
- **Line monitoring of wire-break/short-circuit**
- **Galvanic separation of input circuits, output circuits and supply voltage**
- **Rotation speed monitoring of over/underspeed and window function**
- **Operating range 0.06 ... 600,000/min**
- **Sensor control acc. to EN60947-5-6 (NAMUR)**
- **Connection of 3-wire sensors and external voltage supply 5 ... 30 VDC**
- **2 relays and 1 transistor output**
- **Pulse divider**
- **Current output 0/4...20 mA reversible**
- **Pulse output**
- **Analog output adjustable in the event of input circuit errors**
- **FDT/DTM with diagnostic function**
- **HART**
- **Ring buffer for measured values**
- **Removable terminal blocks**
- **Galvanically separated input circuits, output circuits and supply voltage**

**Rotation speed monitor
single-channel
IM21-14-CDTRI**

Dimensions

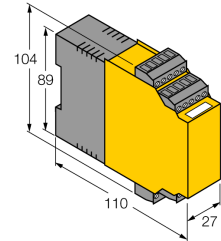

Type	IM21-14-CDTRI
Ident-No.	7505650
Nominal voltage	Universal voltage supply unit
Operating voltage range	20...250 VAC
Frequency	≥ 40...≤ 70 Hz
Operating voltage range	20...250 VDC
Power consumption	≤ 3 W
Monitoring range / setting range:	≤ 0.06...600000 min ⁻¹
Input frequency	600000 min ⁻¹
Pulse time	≥ 0.02 ms
Pulse stop	≥ 0.02 ms
NAMUR	EN-60947-5-6
No-load voltage	8.2 VDC
Short-circuit current	8.2 mA
Input resistance	1 kΩ
Cable resistance	≤ 50 Ω
Switch-on threshold:	1.55 mA
Switch-off threshold:	1.75 mA
Wire breakage threshold	≤ 0.1 mA
Short-circuit threshold	≥ 6 mA
3-wire input	
No-load voltage	12 VDC
Current	≤ 20 mA
Input resistance	600 Ω
0-signal	0...3VDC
1-signal	5...30 VDC
External signal source	
0-signal	0...3 VDC
1-signal	5...30 VDC
Input resistance	26000 Ω
Output current	0/4...20 mA
Load resistance current output	≤ 0.6 kΩ
Fault current	0 / 22 mA einstellbar
Output circuits (digital)	2 x relays (NO)
Relay switching voltage	≤ 250 VAC/120 VDC
Switching current per output	≤ 2 A
Switching capacity per output	≤ 500 VA/60 W
Switching frequency	≤ 10 Hz
Voltage drop	≤ 2.5 V
Contact quality	AgNi, 3μ Au
Semiconductor output circuit(s)	
Output circuits (digital)	1 x transistor (potential-free, short-circuit protected)
Switching voltage	≤ 30 VDC
Switching current per output	≤ 50 mA
Switching frequency	≤ 10000 Hz
Pulse output	
Voltage	≤ 30 V
Current	≤ 10 mA
Measuring accuracy	≤ 0.1 % of full scale
Galvanic isolation	
Test voltage	2.5 kV
Rated voltage	250 V
Indication	
Operational readiness	green
Switching state	yellow
Error indication	red

**Rotation speed monitor
single-channel
IM21-14-CDTRI**

Protection class	IP20
Ambient temperature	-25...+70 °C
Storage temperature	-40...+80 °C
Dimensions	104 x 27 x 110 mm
Weight	247 g
Mounting instruction	Mounting on DIN rail or mounting panel
Housing material	Polycarbonate/ABS
Electrical connection	4 x 5-pole removable terminal blocks, reverse polarity protected, screw connection
Terminal cross-section	1 x 2.5 mm ² / 2 x 1.5 mm ²